



BCP Series AC EV Charger

Use and Installation Manual

WWW.BENY.COM

ZHEJIANG BENYI NEW ENERGY CO.,LTD.

WENZHOU BRIDGE INDUSTRIAL ZONE, BEIBAIXIANG TOWN, ZHEJIANG, CHINA

TEL: +86-577-5717 7008 FAX: +86-577-5717 7007

VERSION: 20230201

✉ benyi@zjbeny.com

🌐 www.beny.com

♻️ This catalogue has been printed on ecological paper.

© Zhejiang Benyi New Energy Co., Ltd. All rights reserved.

⚠️ If the models and specification in this product catalogue is changed due to the change of products, we will not inform.



Scan For
More Information



CONTENTS

Safety information

- Important safety instructions P-01
- Cautions P-02
- Notes P-02
- Specification P-03
- Power Comparison Table P-03
- Features P-04

Prepare for installation

- Minimum installation requirements P-05
- Position P-06
- Height P-06
- Maximize Wi-Fi signal reception(for models with Wi-Fi function) P-06
- Power supply P-07
- Installation considerations P-08

In the box

- In the box P-09

Installation instructions

- Step-by-step installation instructions (bottom entry wiring) P-10
- Step-by-step installation instructions (top entry wiring) P-12
- Step-by-step installation instructions (rear entry wiring) P-14
- Set the operating current P-16
- Reinstall the sealing cover and turn on power P-16

Operating status

- Power on checking P-17
- Button P-17
- LED lights instructions P-18
- Buzzer prompt description P-22
- Start to use? Download the APP here P-22

Maintenance instructions

- Product overhaul P-23
- Warranty description P-23
- Safety notice
Operation and maintenance risk notification P-24
- Use risk notification P-24

DLB Installation instructions

- 1 Phase Grid P-25
- 2 Phase Grid P-26
- 3 Phase Grid P-27
- 2 Live wire 1 earth wire power supply method P-28

Safety information

➤ Important safety instructions

This document contains important instructions and warnings that must be followed when installing and maintaining the EV Charger.

⚠ Warning

- ⚠ Read this entire mandatory document before installing or using the EV charger.
- ⚠ This device should be supervised when used around children.
- ⚠ The BCP series EV Charger must be grounded through a permanent wiring system or an equipment grounding conductor.
- ⚠ Do not install or use the EV Charger near flammable, explosive, harsh, or combustible materials, chemicals, or vapors.
- ⚠ Use the EV Charger only within the specified operating parameters.
- ⚠ Never spray water or any other liquid directly at the wall mounted EV Charger. Never spray any liquid onto the charger handle or submerge the charger handle in liquid. Store the charger handle above the ground to prevent unnecessary exposure to contamination or moisture.
- ⚠ Stop using and do not use the EV Charger if it is defective, appears cracked, frayed, broken, or otherwise damaged, or fails to operate, or continue operation.
- ⚠ Do not attempt to disassemble, repair, tamper with, or modify the EV Charger. The EV Charger is not user serviceable. Contact us for any repairs or modification.
- ⚠ Transporting the EV Charger, handle with care. Do not subject it to strong force or impact or pull, twist, tangle, drag, or step on the EV Charger, to prevent damage to it or any components.
- ⚠ Do not touch the EV Charger's end terminals with sharp metallic objects, such as wire, tools, or needles.
- ⚠ Do not forcefully fold or apply pressure to any part of the EV Charger or damage it with sharp objects.

Safety information

- ⚠ Do not insert foreign objects into any part of the EV Charger.
- ⚠ Use of the EV Charger may affect or impair the operation of any medical or implantable electronic devices, such as an implantable cardiac pacemaker or an implantable cardioverter defibrillator. Check with your electronic device manufacturer concerning the effects that charging may have on such electronic devices before using the EV Charger.

➤ Cautions

- ⚠ Do not use private power generators as a power source for charging.
- ⚠ Incorrect installation and testing of the EV Charger could potentially damage either the vehicle's Battery and/or the EV Charger itself. Any resulting damage is excluded from New Vehicle Limited Warranty and the EV Charger Limited Warranty.
- ⚠ Do not operate the EV Charger in temperatures outside its operating range of -25°C to +55°C.
- ⚠ That adaptors or conversion adaptors are not addowed to be used.
- ⚠ That cord extension sets are not allowed to be used.

➤ Notes

- Ensure that the EV Charger's charging cable is positioned so it will not be stepped on, driven over, tripped on, or subjected to damage or stress.
- Do not use cleaning solvents to clean any of the EV Charger's components. The outside of the EV Charger, the charging cable, and the connector end of the charging cable should be periodically wiped with a clean dry cloth to remove accumulation of dirt and dust.
- Be careful not to damage the circuit board when removing the power entry knock-out.

Safety information

> Specification

Description	Specification
Voltage and wiring	Single-phase or three-phase EV Charger: AC230V±10%; L1、N、PE Three-phase EV Charger: AC400V±10%; L1、L2、L3、N、PE
Current	6A/8A/10A/12A/16A/20A/25A/32A
Frequency	50/60HZ
Cable length	5M/6M
EV charger dimensions	Height: 380mm Width: 169mm Depth: 151/201mm
Gross Weight	7KG/5KG
Operating temperature	-25°C~55°C
Enclosure rating	IP65(Socket IP55)
Standby power	2W
Humidity	<95%No condensation
Altitude	≤2000M
Leakage detection	TYPE A + DC6mA leakage sensor built-in

> Power Comparison Table

	Voltage(V)	Current(A)	Power(W)
1-Phase EV Charger	230	6	1380
	230	8	1840
	230	10	2300
	230	12	2760
	230	16	3680
	230	20	4600
	230	25	5750
	230	32	7360
3-Phase EV Charger	230	6	4140
	230	8	5520
	230	10	6900
	230	12	8280
	230	16	11040
	230	20	13800
	230	25	17250
	230	32	22080

Safety information

> Features

- Build-in with overvoltage and under-voltage protection($U > 264V$ or $U < 187V$), over-current protection, over temperature protection, imperfect earth detection, CP abnormal signal protection and type A + DC 6mA for europe standard.
- Operating temperature range: $-25\text{ }^{\circ}\text{C} \sim +55\text{ }^{\circ}\text{C}$
- IP65(Socket IP55)protecting rate, operating humidity range 0-95% for indoor and outdoor.
- With temperature sensor build-in important areas for fire protection.
- With leakage test function, ensure the normal operation of leakage protection.
- The charger has a function of automatic reset after troubleshooting. That means when a charger stop working when an anomaly is detected, the charger will periodically self-check whether the anomaly is eliminated. The charger will start to work automatically after ensure the anomaly has been eliminated.
- Easy for cable storage.
- The ramp-down stop current charging mode protects the EV batteries.
- The EV charger can be wall-mounted or pile mounted. There are three wiring ways for the EV charger, bottom entry wiring, Top entry wiring and rear entry wiring. You will need to install the wiring box to make top entry wiring.
- RFID card or auto-start charging for option.
- Rated charging current can be set according to different home load conditions.
- With lightning protection ensure personal safety.
- Standard: EN IEC 61851-1:2019 IEC 61851-1:2017
- Certificate: CE/CB/UKCA/SAA

Prepare for installation



> Minimum installation requirements

Installation of the wall charger requires that you:

- Calculate the existing electrical load to determine the maximum operating current.
- Calculate the distance to ensure minimal voltage drop.
- Obtain any necessary permits from the local authority that has jurisdiction and confirm that the follow-up inspection has been scheduled by an electrician after the installation is complete.
- Use only copper conductors.
- Use copper wire that meets the specifications of local wiring regulations. The selected cable must be capable of withstanding continuous loads of up to 40A at all times. The selected circuit protection device must incorporate an appropriate wall-mounted residual current device (RCD) and corresponding electrical load over current protection.

Prepare for installation

> Position

- Ensure that the parking position is within range of the charging cable.
- There is enough clearance for the charging cable to wrap around and the charging handle can be comfortably positioned on the side of base.
- If installed in an enclosed garage, choose to install on the side of the EV charger slot.
- For outdoor installations, waterproof protection is recommended but not mandatory.
- Install in a well-ventilated space. Avoid installation in enclosed boxes or close to high power appliances.

> Height

- Maximum height (indoor and outdoor): 60 inches (1.5 m)
- Recommended height: 47 in (~1.2 m)
- Minimum outdoor height: 24 in (0.6 m)
- Minimum interior height: 18 inches (0.45 m)

> Maximize Wi-Fi signal reception (for models with Wi-Fi function)

- For achieving optimal functionality, the Wall Mounted Connector should be connected to the local Wi-Fi network. To maximize signal reception, avoid installing wall-mounted connectors against physical obstacles such as concrete, masonry, metal poles, etc. that may prevent Wi-Fi signal reception.
- Note: If the mobile device can connect to local Wi-Fi in a specific location, the wall-mounted connector can also be connected.



Prepare for installation

➤ Power supply

• 230V single-phase power supply

- For single-phase EV charger, a single-phase wire (L), Neutral and earth wire must be connected. The phase voltage between the Line and Neutral wires should be 230V.
- For 3-phase EV charger, connect the single phase wire (L1), the neutral wire and the earth wire do not connect the other phase wires (L2 or L3). The phase voltage between the line and neutral wires should be 230V.

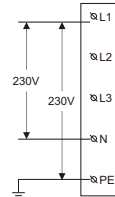
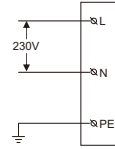

• 400V three-phase power supply with neutral line

- If three phases are applied, all three phases (L1, L2 and L3) and the neutral line should be connected to each other and the voltage of each phase to the neutral line should be 230V.

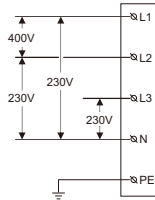

⚠ Warning

- ⚠ Normally, the earth wire should be properly connected, otherwise the EV charger will not work.
- ⚠ For situations where there is no earth connection, in order to enable the EV Charger to operate, it can be set via APP to turn off the earth detection and it will work, but it will reduce to the leakage protection safety level.
- ⚠ This BCP series AC EV charger must be grounded via a permanent electrical system or equipment grounding Conductor.
- ⚠ Before installing an AC EV charger, please confirm the type of grid connection available. If you are unsure of the type of connection available on the service panel, please consult an electrician or contact ZJBENY for assistance.
- ⚠ Note: Please consult your local electrician or refer to your local code in order to choose the proper wire for the AC EV charger current.

Prepare for installation

➤ Installation considerations

- Three methods are available to install the EV charger. The location of the conduit determines which installation method to follow. If the conduit runs along the floor or low on the wall, use the bottom entry configuration. If the conduit comes from inside the wall, use the rear entry configuration. If the available conduit comes from the ceiling, use the top entry installation.
- Note: Throughout the manual, "conduit" is used as the standard term for the protective tubing that houses the service wiring. In regions where conduit is not used (Europe for example), a cable comprised of service wiring enclosed in a protective jacket may be substituted for conduit if allowed by local regulations.
- Here are some additional guidelines
- Conduit openings are sized for (32 mm) conduit.
- Conduit needs to be metal and flame retardant.
- Use an appropriate circuit breaker.
- To keep the housing weatherproof, use cable glands.
- The ev charger doesn't come with the battery for safety shipping, we advise the users to buy the CR1220 battery or same size battery if need the history record function. Without the battery, the function or the settings need to be reset after charger restart.

In the box



Installation instructions

➤ Step-by-step installation instructions (bottom entry wiring)

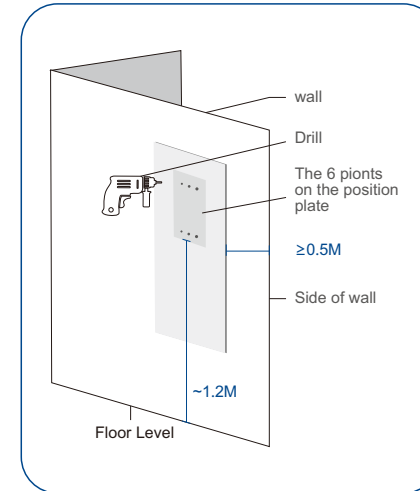

Step 1

Position

The bottom of the ⑨ positioning plate is 1.2 m away (recommended), if the EV charger is installed close to the edge of the wall, the positioning plate should be more than 0.5 m away from the edge of the wall.

Drilling pilot holes

Drilling the holes according to the instruction on the Position template for different installation and wiring ways.

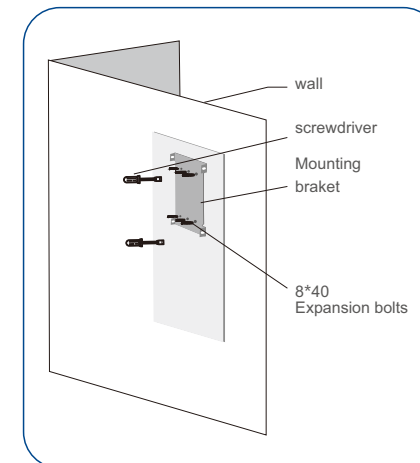

Step 2

Install the Mounting bracket

Put the 8*40 Socket head screws' anchoring into the holes, and use the screw driver make the 6pcs 8*40 Socket head screws to fix the Mounting bracket on the wall .

Installation instructions

Step-by-step installation instructions (bottom entry wiring)

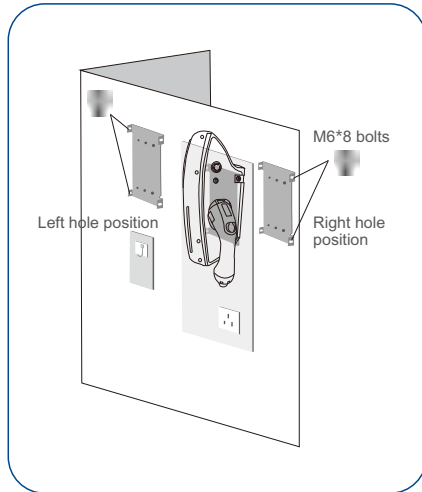

Step 3

Install the EV Charger to the mounting plate

Align the side hole of EV charger to the panel's side holes.

Installation

Use the 4pcs M6*8 screws to fix the EV charger to the mounting plate as picture shows (Screws torque 1.5NM-2.0NM).

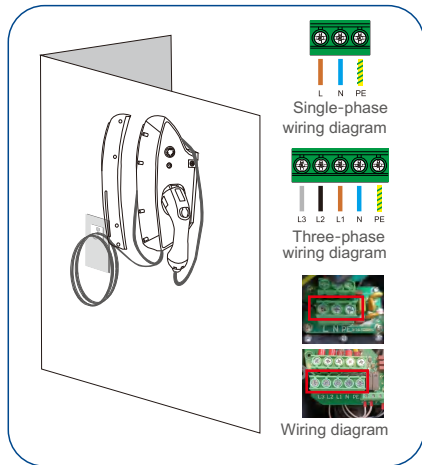

Step 4

Wiring

Note: Consult with your local electrician or refer to your local code for proper wire sizing appropriate for the currents in your EV Charger.

Note: It is the installer's responsibility to identify whether additional grounding is required to ensure that local regulations are met. Grounding must be installed at the power source and not at the cable entry to the EV Charger.

As the picture at left shows, use the screwdriver loosening the screws on the EV charger cover. Wire the cable to the according terminal.

Installation instructions

Step-by-step installation instructions (top entry wiring)

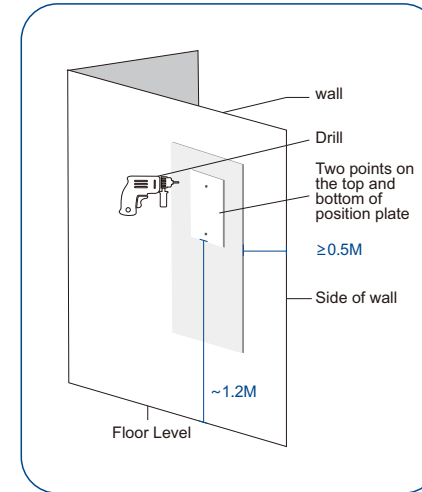

Step 1

Position

The bottom of the ⑨positioning plate is 1.2 m away (recommended), if the EV charger is installed close to the edge of the wall, the positioning plate should be more than 0.5 m away from the edge of the wall.

Drilling pilot holes

Drilling the holes according to the instruction on the Position template for different installation and wiring ways.

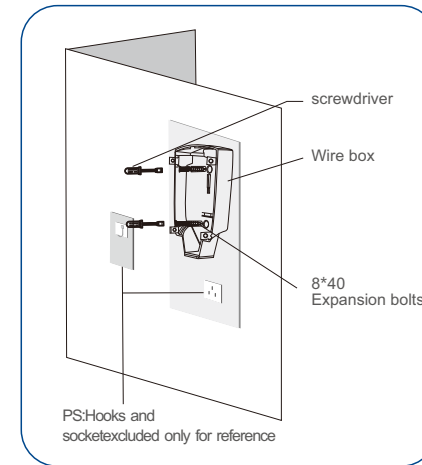

Step 2

Fix the wire box

Put the 8*40 flat head screws' anchoring into the holes and use the screw driver make the 2pcs 8*40 flat head screws to fix the Wire box Mounting Template on the wall.

Installation instructions

➤ Step-by-step installation instructions (top entry wiring)

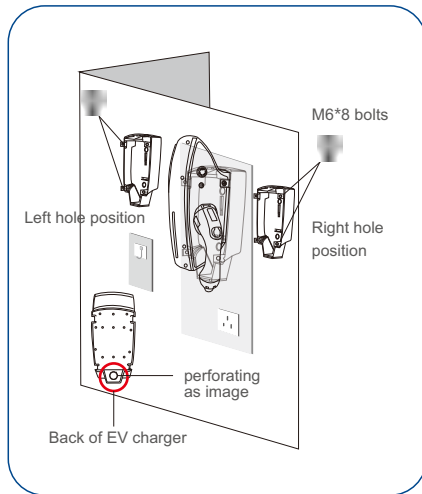

Step 3

Cut out on the back of the EV charger.

Find the hole for cut out on the back of EV charger.

Use the 4pcs M6*8 screws to fix the EV charger to the mounting plate as picture shows (Screws torque 1.5NM-2.0NM).

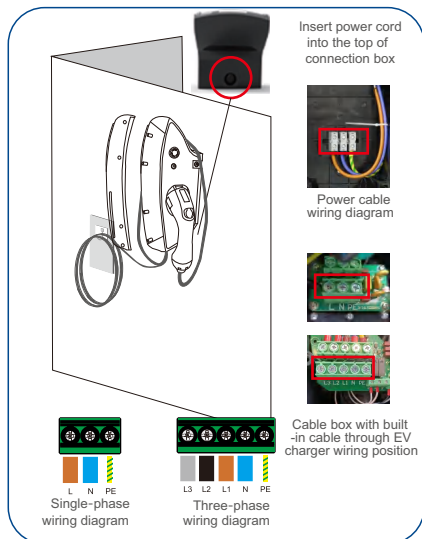

Step 4

Wiring

Note: Consult with your local electrician or refer to your local code for proper wire sizing appropriate for the currents in your EV Charger.

Note: It is the installer's responsibility to identify whether additional grounding is required to ensure that local regulations are met. Grounding must be installed at the power source and not at the cable entry to the EV Charger.

As the picture at left shows, use the screwdriver loosening the screws on the EV charger cover. Wire the cable to the according terminal.

Installation instructions

➤ Step-by-step installation instructions (rear entry wiring)

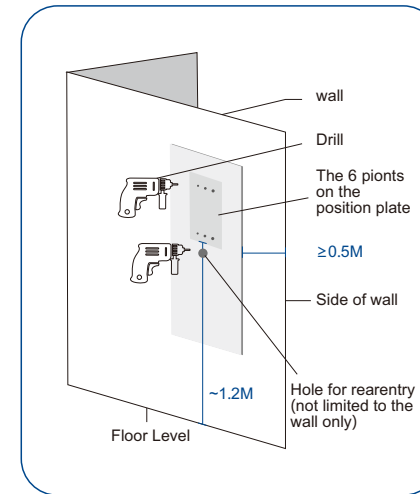

Step 1

Position

The bottom of the ⑨ positioning plate is 1.2 m away (recommended), if the EV charger is installed close to the edge of the wall, the positioning plate should be more than 0.5 m away from the edge of the wall.

Drilling pilot holes

Drilling the holes according to the instruction on the Position template for different installation and wiring ways.

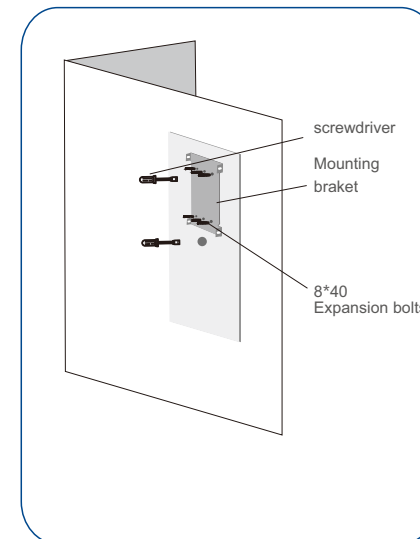

Step 2

Install the Mounting bracket.

Put the 8*40 socket head screws' anchoring into the holes, and use the screw driver make the 6pcs 8*40 Socket head screws to fix the mounting bracket on the wall .

Installation instructions

➤ Step-by-step installation instructions (rear entry wiring)

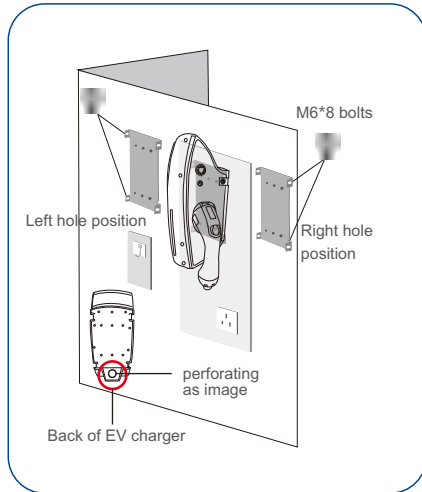

Step 3

Install the EV Charger to the mounting plate.

Find the hole for cut out on the back of EV charger.

Use the 4pcs M6*8 screws to fix the EV charger to the mounting plate as picture shows (Screws torque 1.5NM-2.0NM).

Step 4

Wiring

Note: Consult with your local electrician or refer to your local code for proper wire sizing appropriate for the currents in your EV Charger.

Note: It is the installer's responsibility to identify whether additional grounding is required to ensure that local regulations are met. Grounding must be installed at the power source and not at the cable entry to the EV Charger.

As the picture at left shows, use the screwdriver loosening the screws on the EV charger cover. Wire the cable to the according terminal.

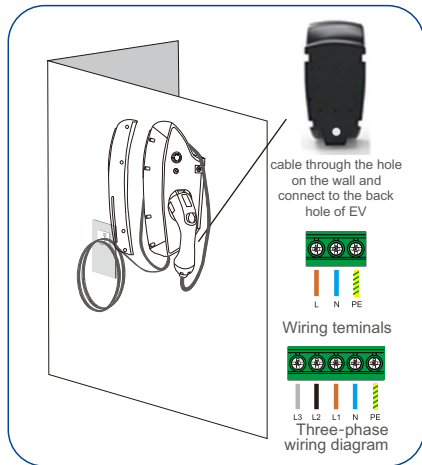

Installation instructions

⚠ Warning

- Do not connect the power cord before reading and fully understanding all the concepts introduced in this section. If you are not sure whether the type of power supply on the repair panel is available, please consult an electrician for assistance.
- Be careful of electric shock! Before use, use a voltmeter to confirm that there is no voltage on the power supply line or terminal to ensure that the power has been cut off.

➤ Set the operating current

- After installation, users can set the maximum operating current of the EV charger in the APP, Please refer to APP manual for details.

➤ Reinstall the sealing cover and Turn on power



- ①. Use a screwdriver to lightly secure the sealing cover by installing only the top screws at (1.5NM-2.0NM) torque.
- ②. After sealing cover fixing, put the fascia on and fix it on the sealing cover.
- ③. If you need to open the front cover, change the internal settings, please use the ④ plastic lifter to unclench along the edge of the cover.
- ④. Recommend to install a circuit breaker 40A/2P 30MA.

Operating status

> Power on checking

NO.	Check content
1	Check and ensure the circuit breaker for the EV charger is reasonably selected
2	Confirm that there is no short circuit between the AC output L/N/PE of the charging
3	Confirm that the charging gun is not connected to the vehicle
4	Ensure the circuit breaker is closed
5	The charger is powered on, and the power-on selfcheck is completed in about 10 seconds
6	After the power-on self-check is completed, observe the status of the LED indicator. Normal standby: Green breathing light ON. Equipment Failure: Yellow light on /Red light on (Please find below for reference)

> Button



- Emergency stop reset button
- Leakage test button





- Emergency stop reset button: After press the button, yellow light is always on, EV Charger function is suspended. Rotate the button counterclockwise to recover from EV Charger faults.
- Electric leakage test button: Press the button to test the electric leakage(if the red light is flashing, the EV Charger detection function of electric leakage is normal), keep pressing the leakage test button for 10s, the EV Charger connection mode is initialized to Bluetooth mode. (smart types only)

Operating status



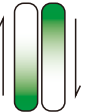

> LED light instructions

Normal Status				
LED Behavior	LED Status	Status Description	Potential Cause	Solution
	Lights OFF	No power supply	No power	Check the power source
	All lights ON, Yellow and Green lights are blinking till green lights breathing magenta.	Charger Power ON self test		
	The first green light breathing magenta.	Standby		
	The 1-6 green lights ON, brightness decreases from top to bottom	RFID initiated while standby		

Operating status

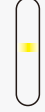
Normal Status				
LED Behavior	LED Status	Status Description	Potential Cause	Solution
	Green lights up and down	No RFID card swiping EV is not ready		
	Green lights end in the middle	After RFID swiping EV is not ready		
	Green lights extend from the middle to the ends	Charging		
	All green lights ON	Charging finished		

Operating status

Fault Status				
LED Behavior	LED Status	Status Description	Potential Cause	Solution
	All lights strobe (4 times per second)	Contactora failure	Contactora adhesion or tripping	Check whether the vehicle charging module is normal
	Yellow lights ON	Emergency stop protection	Emergency stop button is pressed	Rotate the emergency stop button Pop-up reset
	Red lights ON	Grounding abnormality	The ground wire is not wired or the neutral wire is reversed	Check whether the grid connection and charger wiring is correct
	Red light once	Over Voltage	Power supply has short circuit or unstable	1.Check the power supply 2.Check the wire of power supply
	Red light twice	Under Voltage	Power supply voltage is insufficient	1.Check the power supply 2.Check the wire of power supply
	Red light thrice	Leakage fault	Leakage happens	1.Reset with emergency stop button 2.Check the charger connector or vehicle for leakage

Operating status

Fault Status				
LED Behavior	LED Status	Status Description	Potential Cause	Solution
	Red light flashes continuously (Once per second)	Over current	Short circuit may happen	Call for professional repair
	Red light flashes (Quartic per second)	Over temperature alarm	High temperature	1.Wait for charger cooling 2.Ensure the wiring of charger terminal is not losing
	Alternating red and yellow continuously Red for 0.5 seconds followed by yellow for 0.5 seconds	Abnormal CP signal	The connection between the charger and the vehicle is loose	1.Check if the connector is with water leakage in 2.Ensure the connector is matched with EV
	Red and yellow lights flash once	Abnormal CC signal	The connection between the charger and the vehicle is loose	Check whether the charger connector is firmly inserted
	Yellow light ON triple	LED board is offline	LED board is fault or losing	Open the charger cover and check whether the light board cable is connected correctly and firmly
	Yellow light ON once, red light ON once	DLB is offline	The DLB connection is loose	Check the connection between DLB box and charger
	Yellow light ON once, red light ON twice	DLB abnormal	The connection between the DLB box and the CT is loose or the CT is not clamped	1.Check the CT of the DLB box is in the correct position 2.Check whether the DLB box CT is firmly clamped 3.Check if the phase sequence of the DLB box CT is correct 4.Check if the connection between the DLB box CT and the DLB box is firm

Operating status

Buzzer prompt description

Buzzer	Status	Operating
Short buzzing one sound	Swipe to start	Start charging
Short buzzing two sounds	Swipe to quit	Stop charging
Long buzzing one sound	Swipe failure	NONE

Start to use? Download the APP here

Android

Open Google Play



Click Search bar
Input "Z-BOX"

Z-BOX

Find ""Z-BOX""APP"



Z-BOX

Click "Download"

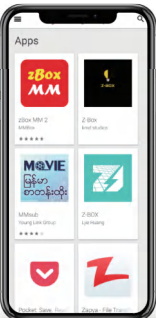

IOS

Open APP Store



Click Search bar
Input "Z-BOX"

Z-BOX

Find ""Z-BOX""APP"



Z-BOX

Click "Download"



Maintenance instructions

In order to ensure the normal service life of the charging pile and reduce the risk during use, it must be overhauled within the specified time period; the overhaul of the equipment should be carried out by professionals, and qualified and safe overhaul tools should be used.

> Product overhaul

- Regularly check whether the product is damaged.
- Ensure that the emergency stop, circuit breaker and other components of the product can be used under any circumstances, and conduct regular tests.
- If a ground fault occurs, first make sure that the grounding cable carries voltage, and then check that there is no high voltage in the system, and then repair the charger.

> Warranty description

- Free warranty is available for any damages or failures due to the chargers' quality problems since 3 years from the date of producing at the factory.
- Any damages caused by failure operations, irresistible natural reasons, wrong install or use against with the instructions, is not covered by the warranty.
- Non-professionals are not allowed to repair the chargers. Any problems during installation or use, please contact the dealer first.

Maintenance instructions

> Safety notice

Operation and maintenance risk notification

- Do not disassemble or modify charging facilities and wiring without authorization, otherwise it may cause fire and electric shock accidents.
- In the event of a power failure or power failure, professional personnel or authorized operation and maintenance personnel must perform maintenance, otherwise there may be a risk of electric shock; charging equipment maintenance is not allowed when the power is not disconnected, and there is a risk of electric shock.
- The emergency stop switch should be inspected and maintained regularly to ensure that the emergency stop switch is effective.
- There should be no combustible and combustible materials around the charging equipment. If there is any, it should be cleaned up in time, otherwise there is a risk of fire.

> Use risk notification

- Please confirm whether the parameters of the electric vehicle and the charging equipment match before use, otherwise it may cause damage to the vehicle.
- It is strictly forbidden to use the charger in the case of equipment failure. Do not operate without authorization when the charging is abnormal. If you find any abnormalities, please contact the staff in time.
- Please strictly follow the operating procedures and prompts on the charging equipment, otherwise there is a risk of electric shock and fire.
- In the event of fire, flooding of charging facilities, etc., it is strictly forbidden to approach the charging equipment. Please inform personnel familiar with the equipment and emergency treatment methods for emergency treatment in time.
- Guardians should take good care of children when they are moving around charging facilities to avoid accidents such as electric shock.

DLB Installation instructions

> 1 Phase Grid

Normal DLB

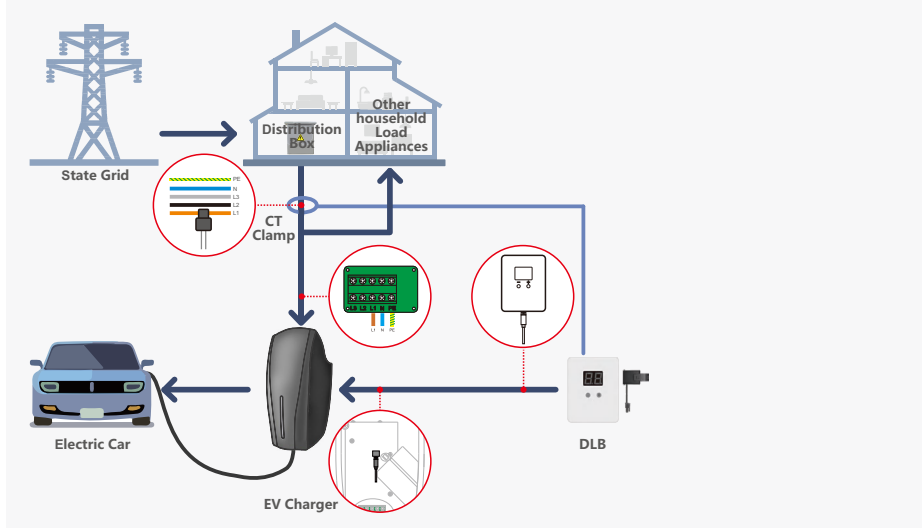

DLB Installation instructions

> 2 Phase Grid

Normal DLB

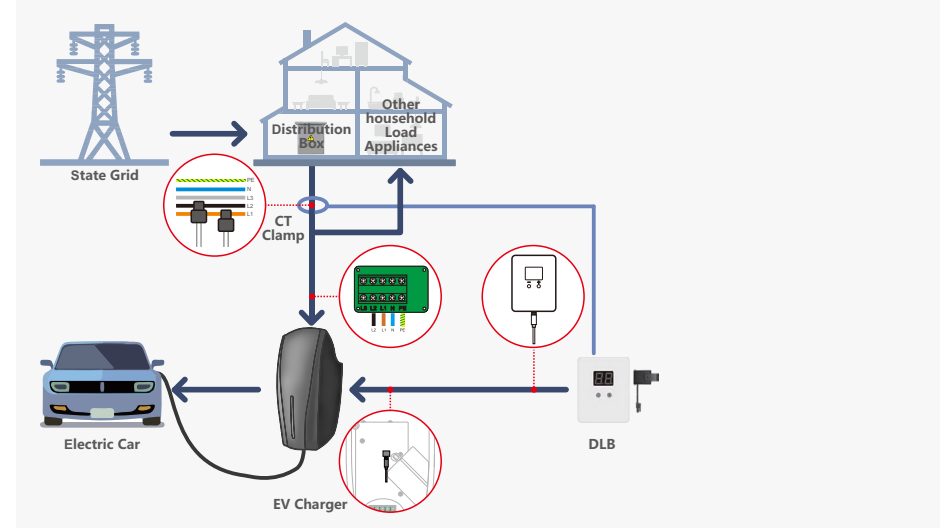

Solar DLB

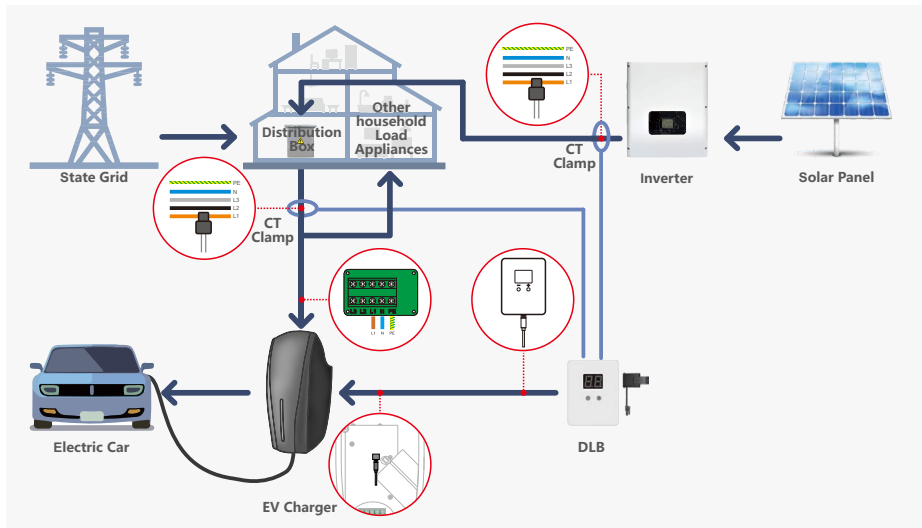

Solar DLB

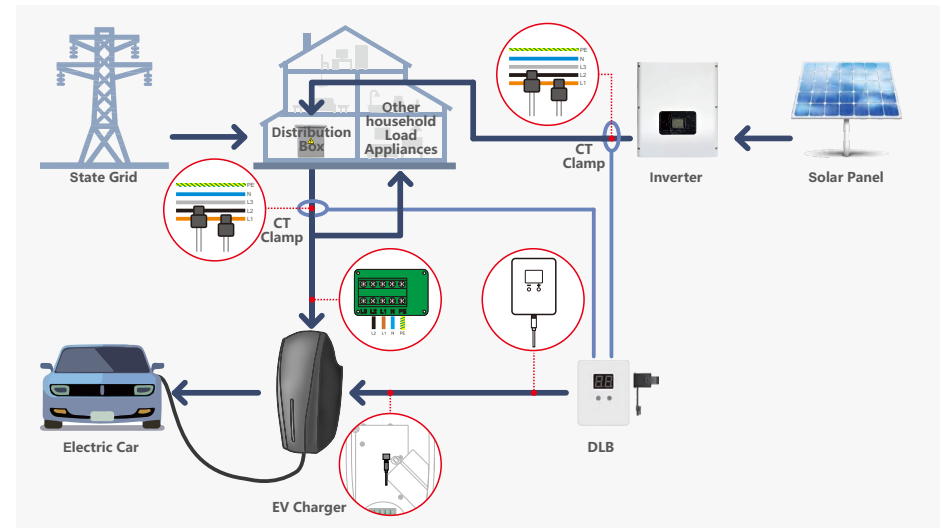

DLB Installation instructions

➤ 3 Phase Grid

Normal DLB

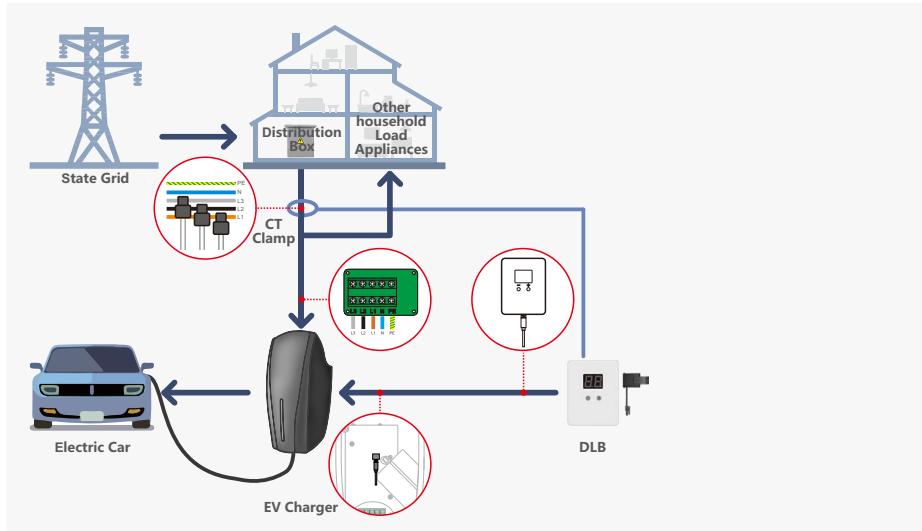

Solar DLB

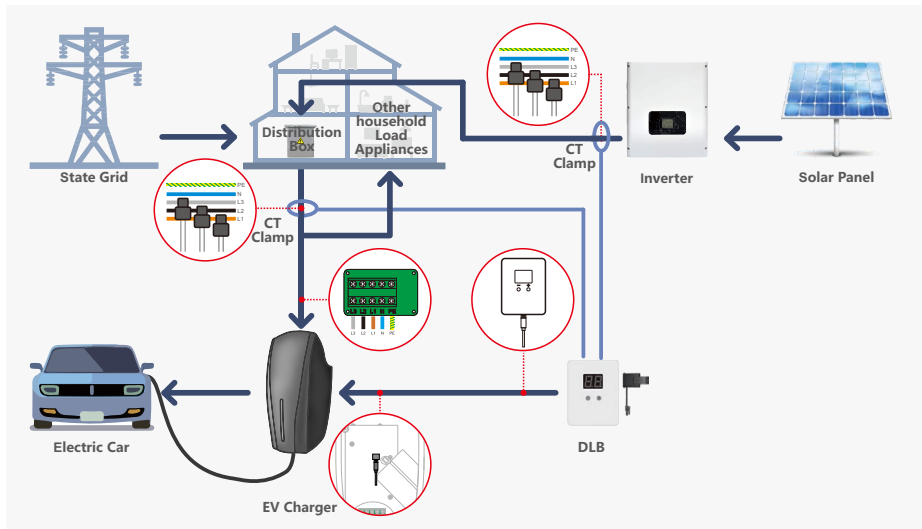

DLB Installation instructions

➤ 2 Live wire 1 earth wire power supply method

Normal DLB

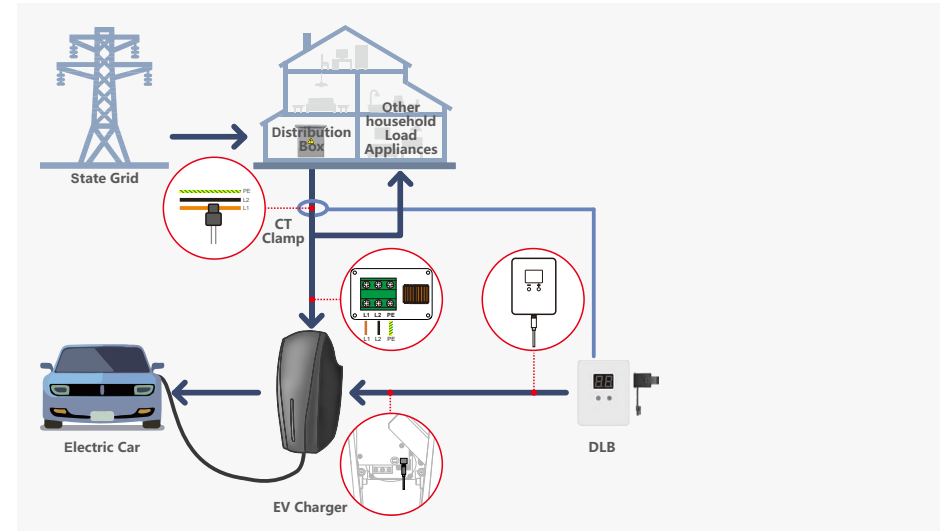

Solar DLB

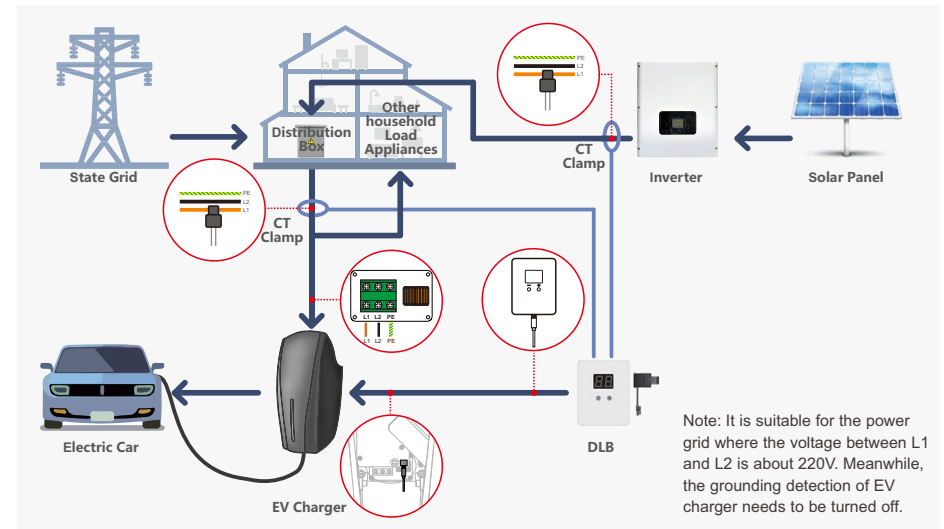

Note: It is suitable for the power grid where the voltage between L1 and L2 is about 220V. Meanwhile, the grounding detection of EV charger needs to be turned off.