



PV Grid-tied Inverter
SPI-B X2 Series (30K-40K)

User Manual

Copyright © Xiamen Kehua Digital Energy Tech Co., Ltd. 2022. All rights reserved.

No part of this document may be reproduced or transmitted in any form or by any means without prior written consent of Xiamen Kehua Digital Energy Tech Co., Ltd.

Trademarks and Permissions



and other Kehua trademarks are the licensed trademarks of Xiamen Kehua Digital Energy Tech Co., Ltd.

All other trademarks and trade names mentioned in this document are the property of their respective holders.

Notice

The purchased products, services and features are stipulated by the contract made between Kehua and the customer. All or part of the products, services and features described in this document may not be within the purchase scope or the usage scope. Unless otherwise specification in the contract, all statements, information, and recommendations in this document are provided “AS IS” without warranties, guarantees or representations of any kind, either express or implied.

The information in this document is subject to change without notice. Every effort has been made in the preparation of this document to ensure accuracy of the contents, but all statements, information, and recommendations in this document do not constitute a warranty of any kind, express or implied.

XIAMEN KEHUA DIGITAL ENERGY TECH CO., LTD.

Address:	No.457, Malong Road, Torch High-Tech Industrial Zone, Xiamen, Fujian, China
Website:	www.kehua.com
E-mail:	service@kehua.com
Customer Service Telephone:	400-808-9986
Tel:	0592-5160516
Fax:	0592-5162166

Foreword

Summaries

Thank you for choosing the PV grid-tied inverter (hereinafter referred to as inverter)!

This document gives a description of the inverter, including appearance, features, working principles, installation, electrical connection, operation, maintenance and storage, etc.

Please save the manual after reading, in order to consult in the future.



NOTE



The figures in this manual are just for reference, for details please see the actual product.





Applicable Model

- SPI30K-B X2
- SPI33K-B X2
- SPI36K-B X2
- SPI36K-B X2P
- SPI40K-B X2
- SPI40K-B X2P

Symbol Conventions

The manual quotes the safety symbols, these symbols used to prompt users to comply with safety matters during installation, operation and maintenance. Safety symbol meaning as follows.

Symbol	Description
	Alerts you to a high risk hazard that will, if not avoided, result in serious injury or death.
	Alerts you to a medium low risk hazard that could, if not avoided, result in moderate or minor injury.

Symbol	Description
 CAUTION	Alerts you to a low risk hazard that could, if not avoided, result in minor injury.
	Anti-static prompting.
	Be care electric shock prompting.
 TIP	Provides a tip that may help you solve a problem or save time.
 NOTE	Provides additional information to emphasize or supplement important points in the main text.

Product standard: Q/XMHS 003

Contents

1 Safety Description.....	1
1.1 Safety Announcements.....	1
1.1.1 Use Announcements.....	1
1.1.2 PV String Protection	2
1.1.3 ESD Protection.....	3
1.1.4 Grounding Requirements	3
1.1.5 Moistureproof Protection	3
1.1.6 Warning Mark Setting	4
1.1.7 Electrical Connection.....	4
1.1.8 Measurement Under Operation	4
1.2 Operator Requirements	5
1.3 Operation Environment Requirements	5
2 Overview.....	6
2.1 Product Intro.....	6
2.1.1 Model Meaning.....	7
2.1.2 Features	7
2.2 Apperance and Structure	8
2.2.1 LED Indicator	8
2.2.2 External Terminal Illustration	9
2.3 Working Principle.....	10
3 Installation.....	11
3.1 Installation Process.....	11
3.2 Installation Preparation	11
3.2.1 Installation Tools.....	11

3.2.2 Installation Environment.....	12
3.2.3 Installation Clearance.....	13
3.2.4 Installation Method.....	14
3.3 Transportation and Unpacking.....	14
3.3.1 Transportation.....	14
3.3.2 Unpacking and Checking.....	14
3.4 Inverter Installation.....	15
3.5 Electrical Connection.....	19
3.5.1 Wire Requirements.....	19
3.5.2 External Grounding Connection.....	19
3.5.3 PV String Input Wiring.....	21
3.5.4 AC Output Wiring.....	24
3.5.5 WIFI/4G Communication Connection.....	26
3.5.6 COM. Communication Connection (Optional).....	28
3.6 Check the Installation.....	31
4 Startup and Shutdown.....	32
4.1 Check Before Startup.....	32
4.2 Start Inverter.....	32
4.3 Shut Down Inverter.....	33
5 Maintenance and Troubleshooting.....	34
5.1 Maintenance.....	34
5.1.1 Inverter Maintenance.....	34
5.1.2 Fan Maintenance.....	35
5.2 Troubleshooting.....	36
6 Stop Running, Dismantle, Discard Inverter.....	39
6.1 Stop Running.....	39
6.2 Dismantle the Inverter.....	40
6.3 Discard the Inverter.....	40
7 Package, Transportation, Storage.....	41

7.1 Package	41
7.2 Transportation	41
7.3 Storage	41
A Technical Specifications	42
B Acronyms and Abbreviations	45

1 Safety Description

This chapter mainly introduces the safety announcements. Prior to performing any work on the device, please read the user manual carefully, follow the operation and installation instructions and observe all danger, warning and safety information.

1.1 Safety Announcements

This section mainly describes the safety announcements when operation and maintenance. For details, please refer to safety description in relevant chapters.

CAUTION

Before operation, please read the announcements and operation instructions in this section carefully to avoid accident.

The promptings in the user manual, such as "Danger", "Warning", "Caution", etc. don't include all safety announcements. They are just only the supplement of safety announcements when operation.

NOTE

Any device damage caused by violating the general safety operation requirements or safety standards of design, production, and usage will be out of Kehua's guarantee range.

1.1.1 Use Announcements

DANGER

Don't touch terminals or conductors that connected with grid to avoid lethal risk!

 **DANGER**

There is no operational part inside the inverter. Please do not open the crust of the inverter by yourself, or it may cause electric shock. The device damage caused by illegal operation is out of the guarantee range.

 **DANGER**

After disconnect the input and output of the inverter, there still has residual energy in the storage capacitor, which may cause electric shock. Do not perform the maintenance until all power sources are switched off for 20 minutes and check that there is no voltage and current in the inverter by the detection equipment.

 **WARNING**

The surface temperature of the inverter may reach to 75°C. During running, please don't touch the surface to avoid scald.

 **CAUTION**

No liquid or other objects are allowed to enter the inverter, or, it may cause inverter damage.

 **WARNING**

In case of fire, please use dry power fire extinguisher. If using liquid fire extinguisher, it may cause electric shock.

1.1.2 PV String Protection

When install PV string in daytime, it necessary to cover the PV string by light-proof material, or the PV string will generate high voltage under sunshine. If touching PV string accidentally, it may cause electric shock or human injury!

 **DANGER**

There exists dangerous voltage between the positive and negative of PV string!

When installing the device, make sure that the connection between inverter and PV string has been disconnected completely. And set warning mark in the disconnected position to avoid reconnecting.

1.1.3 ESD Protection

 **CAUTION**

To prevent human electrostatic damaging sensitive components(such as circuit board), make sure that you wear a anti-static wrist strap before touching sensitive components, and the other end is well grounded.

1.1.4 Grounding Requirements

 **WARNING**

High leakage risk! The inverter must be grounded before wiring. The grounding terminal must be connected to ground, or, there will be the risk of electric shock when touching the inverter.

- When installing, the inverter must be grounded first. When dismantling, the grounding wire must be removed at last.
- Don't damage the grounding conductor.
- The inverter must be connected to protection grounding permanently. Before operation, check the electrical connection to ensure the inverter is grounded reliably.

1.1.5 Moistureproof Protection

 **CAUTION**

Moisture invasion may cause inverter damage!

Observe the following items to ensure the inverter works normally.

- When the air humidity is more than 95%, don't open the door of the inverter.
- In the wet or damp weather, don't open the door of the inverter to maintain or repair.

1.1.6 Warning Mark Setting

In order to avoid accident for unwanted person gets close to the inverter or makes improper operation, observe the following requirements while installing, maintaining or repairing.

- Set warning marks where the switches are to avoid switching them on improperly.
- Set warning signs or safety warning belt in the operation area, which is to avoid human injury or device damage.

1.1.7 Electrical Connection

Electrical connection must be performed according to the description in the user manual and the electrical schematic diagram.



The configuration of PV string, grid level, grid frequency, etc. must meet the technical requirements of inverter.

Grid-tied generation should be allowed by the local power supply department and the related operation should be performed by professionals.

All electrical connection must meet the related country and district standard.

1.1.8 Measurement Under Operation



There exists high voltage in the device. If touching device accidentally, it may cause electric shock. So, when perform measurement under operation, it must take protection measure (such as wear insulated gloves, etc.)

The measuring device must meet the following requirements:

- The range and operation requirements of measuring device meets the site requirements.
- The connections for measuring device should be correct and standard to avoid arcing.

1.2 Operator Requirements

 **CAUTION**

The operation and wiring for inverter should be performed by qualified person, which is to ensure that the electrical connection meets the related standards.

The professional technician must be trained strictly, understand all safety announcements, master correct operations and meet the following requirements:

- Fully familiar with the structure and working principle of the whole PV grid-tied generation system.
- Know well about the related standards of local country and district.

1.3 Operation Environment Requirements

 **CAUTION**

Avoid the inverter suffering directly sunshine, rain or snow to prolong the service life (detail please see 3.2.2). If the installation environment does not meet the requirement, the service life may be influenced.

The operation environment may influence the life span and reliability of device. So, please avoid to use device in following environment:

- The place where temperature and humidity beyond the technical specifications (temperature: $-35^{\circ}\text{C} \sim 60^{\circ}\text{C}$; relative humidity: 0%-95%).
- The place with direct sunshine or rain.
- The place with vibration or impact.
- The place with dust, corrosive material, salt or burnable gas.
- The place with poor ventilation or closed situation.
- The place where close to resident living quarter.

2 Overview

This chapter mainly introduces product appearance, structure, working principles and grid form, etc.

2.1 Product Intro

The inverter converts the DC energy from PV string into AC energy and then feedbacks to power grid, which is suitable for the commercial roof grid-tied system and large power station grid-tied system. The PV grid-tied generation system consists of PV string, PV grid-tied inverter and grid, as shown in Figure2-1.



Figure2-1 PV grid-tied generation system

NOTE

The inverter supports four grid forms, that is TN-S, TN-C, TN-C-S and TT, as shown in Figure2-2.

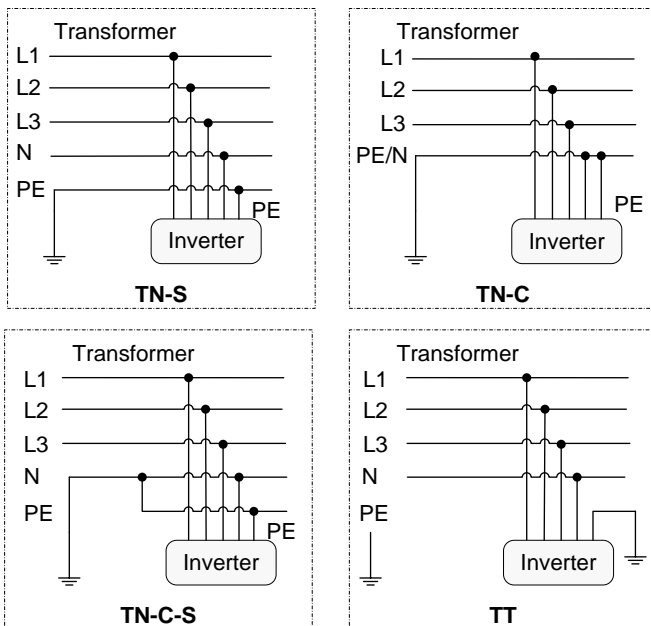

Figure2-2 Grid form



For type TT grid, the effective value of neutral and grounding voltage must be less than 20V.

2.1.1 Model Meaning

The model meaning of SPI-B X2 series (30K-40K) is as shown in Figure2-3.

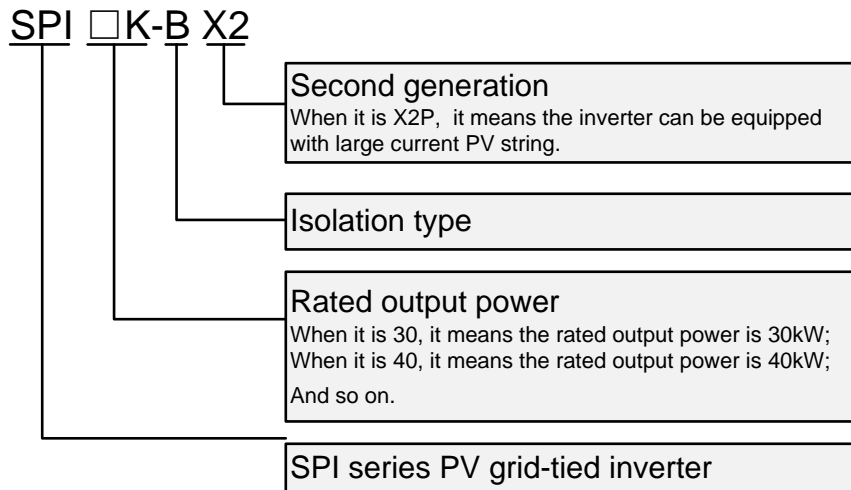

Figure2-3 Model meaning

2.1.2 Features

- Efficiently power generation: adopt high-efficiency type-T three-level high-frequency conversion technology and advanced completely digitized control technology, wide work range of MPPT and high power generation efficiency.
- Safe and reliable: adopt aluminium alloy to diecast the outer case, so that the inverter can work in a widely temperature range. The degree of protection is IP66 and it adopts whole industrial grade electron device.
- Smart manage: adopt smart cloud platform monitor and APP real-time monitor. The inverter supports RS485, WIFI and 4G communication, can connect with DRM and smart meter, and with anti-backflow function. Besides, it can be updated and set the parameters remotely.
- Green and friendly: small size, easy installation and use.
- Better adaptability: with better grid adaptability, wide reactive power adjusting range.

2.2 Appearance and Structure

The appearance of SPI-B X2 series (30K-40K) is as shown in Figure2-4.

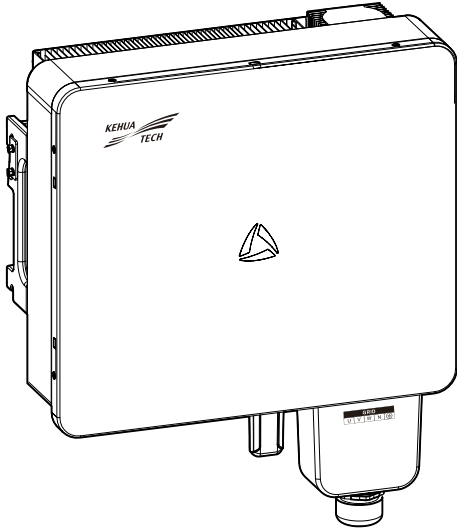







Figure2-4 Appearance

2.2.1 LED Indicator

The LED indicator on the front panel of inverter shows the inverter status, as shown in Table2-1.

Table2-1 LED indicator status illustration

Indicator	Status	Meaning
	Green indicator is on.	Inverter running.
	Green indicator flashes.	Inverter standby.
	Green indicator and red indicator flash alternately.	Inverter fault (not off-grid)
	Red indicator is on.	Inverter fault (off-grid)
	Red indicator flashes.	DC has no input.
	Indicator is off.	AC and DC are powered off.

2.2.2 External Terminal Illustration

The external terminals are all located at the bottom of the inverter, including PV input, AC output, DC switch and communication interface, etc. as shown in Figure2-5.

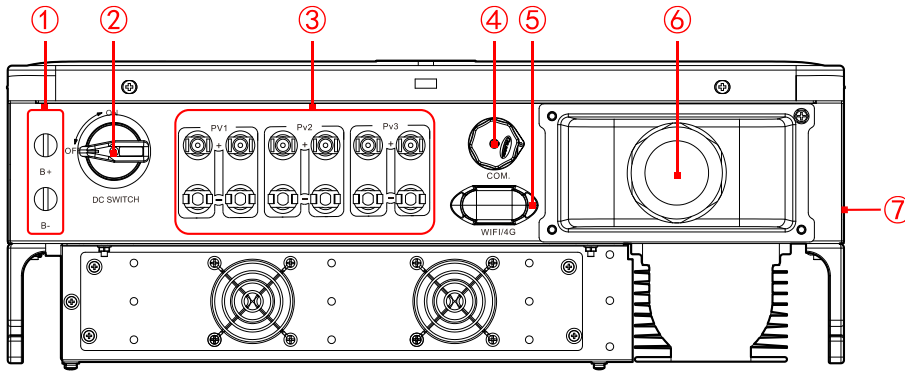



Figure2-5 Bottom layout

Table2-2 Bottom layout illustration

NO.	Mark	Name	Remarks
①	B+/B-	Energy storage interface (reserved)	Connect battery.
②	DC SWITCH	DC switch	DC switch connects inverter with PV string.
③	PV+/PV-	PV string terminal	Connect PV string.
④	COM.	DRM (optional) /RS485 interface	Connect DRM/RS485 wire.
⑤	WIFI/4G	WIFI (optional) / 4G interface	Connect WIFI/ 4G stick.
⑥	AC OUTPUT	AC output wiring hole	Connect AC output wire.
⑦		External grounding terminal	Connect external grounding wire.

DC Switch

The DC switch (as shown in the ② of Figure2-5) connects inverter with the PV string.

- When the inverter works normally, the DC switch must be ON.
- When installation and wiring, the DC switch must be OFF.

- Before maintenance, the DC switch must be OFF for 20 minutes, and measure the voltage of inner DC busbar by multimeter, only when the voltage is less than 10V, the maintenance can be done.

CAUTION

When maintenance or wiring, the DC switch must be disconnected.

2.3 Working Principle

PV strings are connected to inverter, and do the max. power point tracking for PV strings through the three-groups of MPPT circuits inside inverter, and then convert the DC power into the three-phase AC power through the inverter circuit. It also provides surge protection in DC and AC side, as shown in Figure2-6.

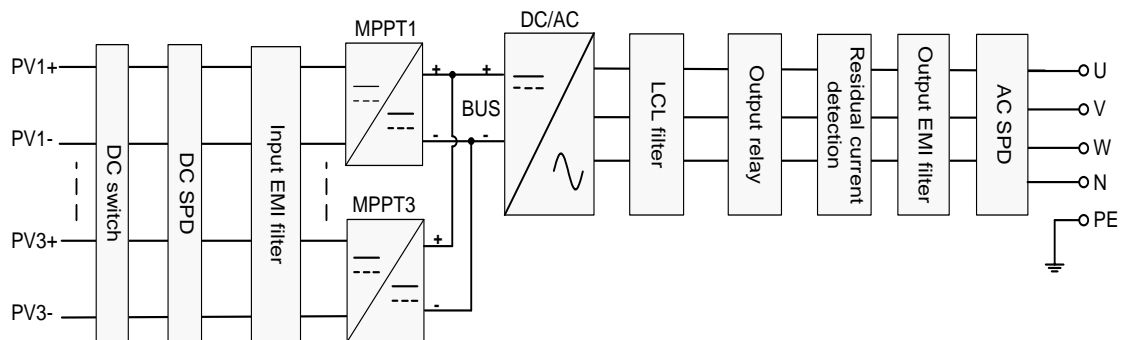

Figure2-6 Working principle diagram

NOTE

When the DC input (PV) has 4 groups of PV strings, the larger power one should be prior to connect with PV1 and PV2.

3 Installation

This chapter mainly introduces the inverter's installation, including installation process, installation preparation, transportation and unpacking, installation procedures, electrical connection. check the installation, etc.

3.1 Installation Process

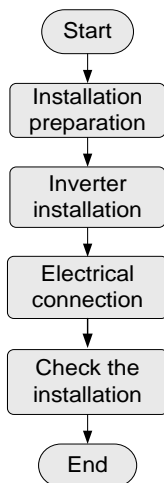

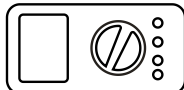

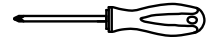

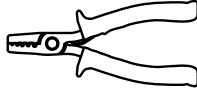
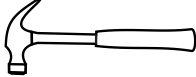
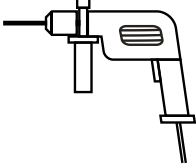
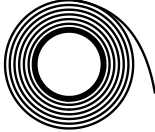
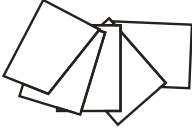

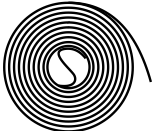
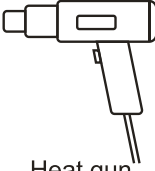

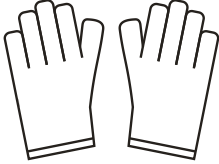
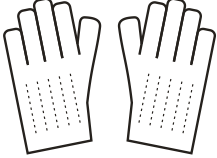
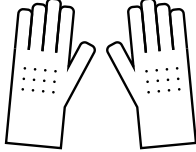



Figure3-1 Installation process

3.2 Installation Preparation

3.2.1 Installation Tools

Tools			
 <p>Clamp meter</p>	 <p>Multi-meter</p>	 <p>Label paper</p>	 <p>Phillips screwdriver</p>

Tools			
 COAX crimping tool	 Diagonal pliers	 Wire stripper	 Claw hammer
 Hammer drill	 Insulation tape	 Cotton cloth	 Brush
 Heat shrink tubing	 Heat gun	 Electrician's knife	 Protective gloves
 ESD gloves	 Insulated gloves	 Hydraulic pliers	 Cable tie

 **CAUTION**

The installation tools need to be insulated to avoid electric shock.

3.2.2 Installation Environment

- Do not install the inverter in the place with poor ventilation.
- Ensure that there has sufficient fresh-air supply around the inverter.
- The inverter must be installed on the wall or bracket with enough bearing capacity.

 **NOTE**

The inverter is rated at IP66. Avoid installing the inverter under sunshine.

Installing the inverter under sunshine or rain or snow will affect the inverter lifespan and efficiency. Installing the inverter under shade is best, as shown in Figure3-2.

The installation height of the inverter should be convenient for viewing the indicator status.



Figure3-2 Recommended installation site

3.2.3 Installation Clearance

Keep a clearance of at least 300mm from the front of the inverter to other objects, at least 250mm from the left side and right side of the inverter to other objects, at least 350mm from the top of the inverter to ceiling and at least 600mm from the bottom of the inverter to ground, which is good for heat dissipation or maintenance, as shown in Figure3-3.

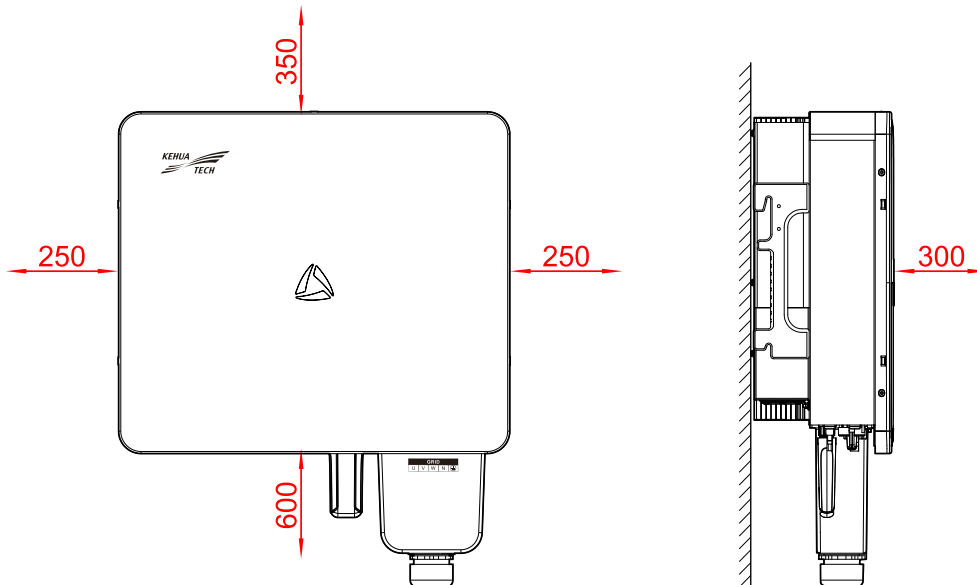

Figure3-3 Installation clearance (unit: mm)

3.2.4 Installation Method

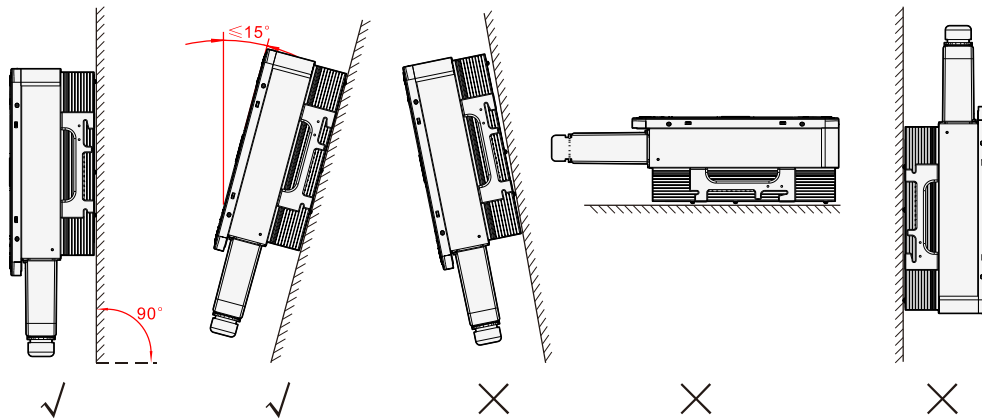

Figure3-4 Installation method

3.3 Transportation and Unpacking

3.3.1 Transportation

The inverter should be transported by trained professional.



During transporting, please take care and avoid impacting or dropping.

During transporting, keep the inverter vertically, do not put it down or put it up suddenly.

3.3.2 Unpacking and Checking

 **NOTE**

Select the unpacking site in advance. In principle, the unpacking site should be as close to the installation site as possible.

The inverter has been tested and checked strictly, but it still may be damaged during transporting, so, please check it carefully.

- Inspect the inverter's appearance, if any shipping damage is found, report it to the carrier immediately.
- Check if the type of the accessories are complete and correct. If there is any discrepancy, take notes and contact the distributor or local dealer immediately.

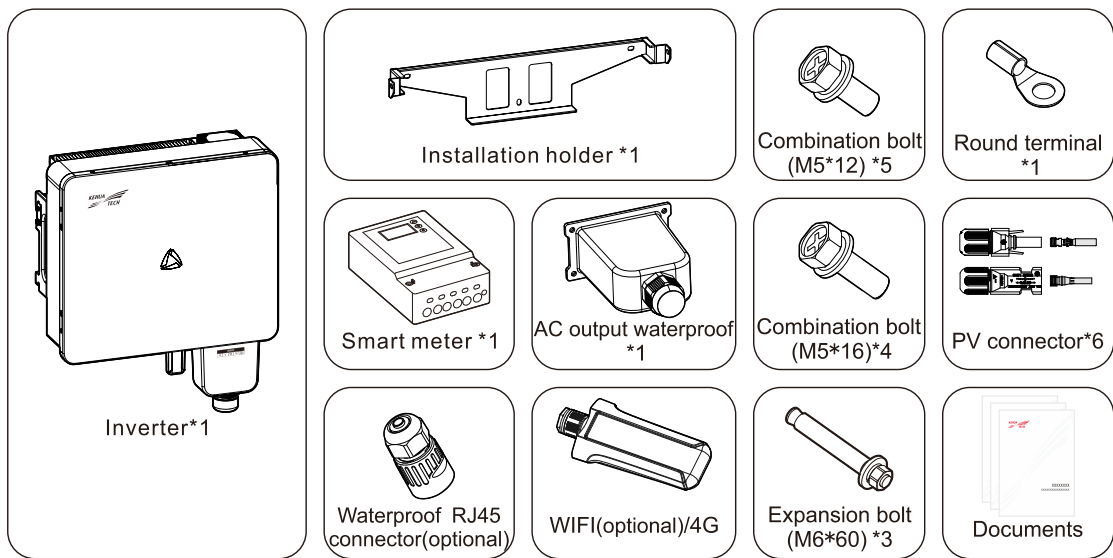

Figure3-5 Packing list

NOTE

1. There are six PV connectors, the actual configuration in order to prevail in kind.
2. WIFI stick, waterproof RJ45 connector and smart meter are optional, they are provided according to the contract.
3. The documents include Installation Guide, QC passed, Packing List, User Service card, Warranty Card, Statement of Toxic and Hazardous Substances, Product Quality Inspection Report, Business License, Solar Energy Certification.

CAUTION

If the inverter needs to be stored for a long time after unpacking, it is necessary to pack the inverter by original package and save properly.

3.4 Inverter Installation

The inverter can be installed on the wall or metal bracket via equipped installation holder. In this section, we take wall installation as example to illustrate, if the inverter needs to be installed on metal bracket, please adjust the installation step correspondingly.

- Step 1 Determine the installation site based on the inverter size (as shown in Figure3-6) and installation clearance (as shown in Figure3-3).

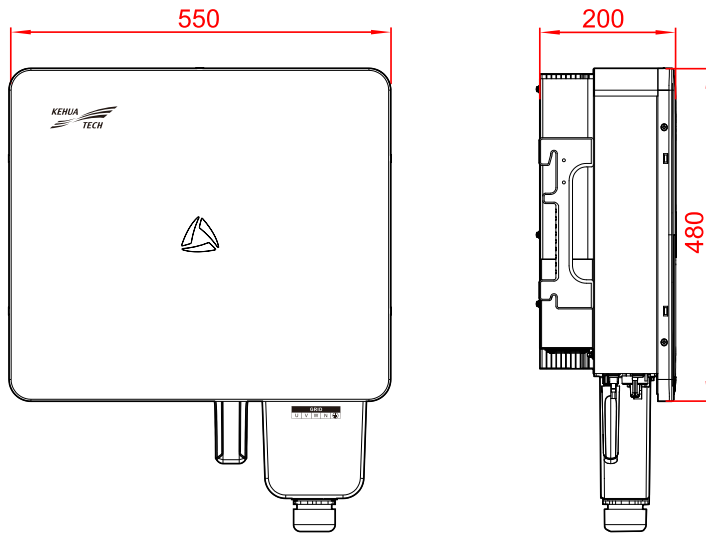

Figure3-6 Size (unit: mm)

Step 2 Mark the position of installation holes on the wall according to the dimensions of the fixing holes of the installation holder (as shown in Figure3-7), and drill three holes of $\Phi 10.5\text{mm}$ on the wall according to marked position, as shown in Figure3-8.

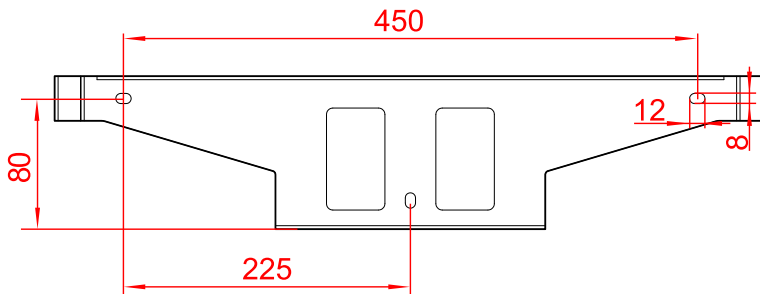

Figure3-7 Installation size (unit: mm)

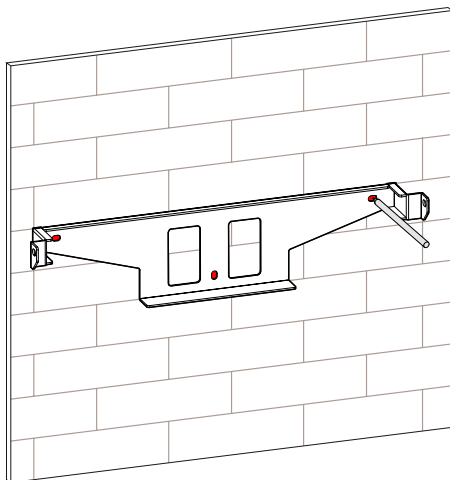

Figure3-8 Mark the drilling position

! CAUTION

When installation, please keep the installation holder horizontal and the installation holes aligned.

NOTE

The depth of drilled holes should be within 40mm. Clear the dust and measure the net depth. Ensure that the depth of three holes is the same.

Step 3 Install the equipped three expansion bolts M6*60 into the holes, as shown in Figure3-9.

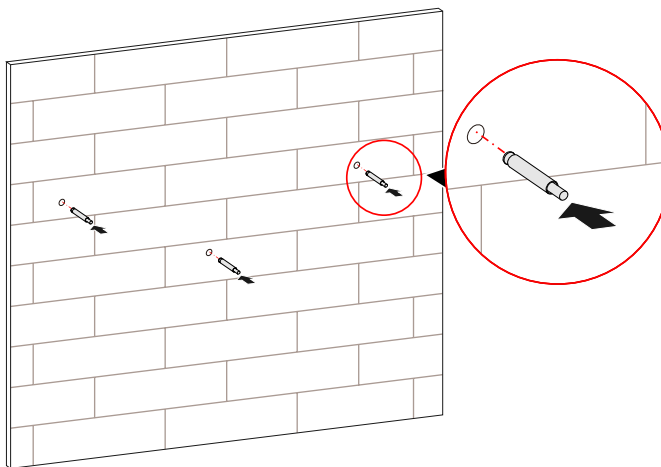

Figure3-9 Install expansion bolts

Step 4 Align the holes of installation holder with the expansion bolts and install the flat gasket, spring gasket and nut into the expansion plugs and fasten them by wrench, as shown in Figure3-10.

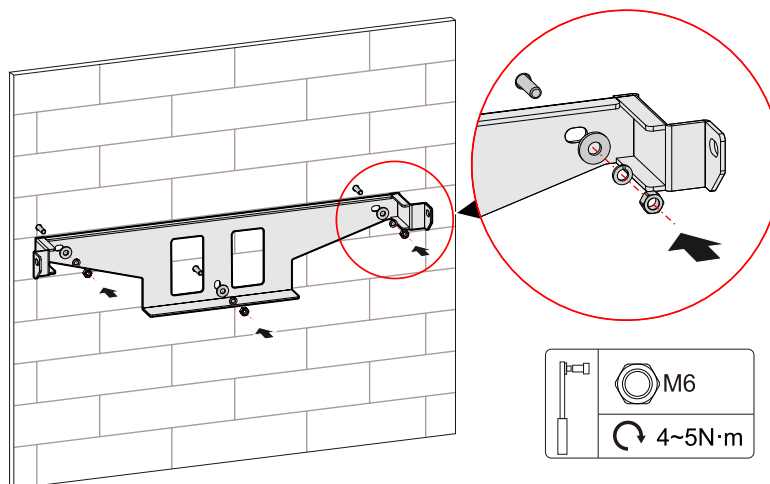

Figure3-10 Fasten the installation holder

Step 5 Uplift the inverter and hang the inverter to the installation holder, as shown in Figure3-11.



Do not loosen the inverter until the inverter has been hung in the installation holder completely.

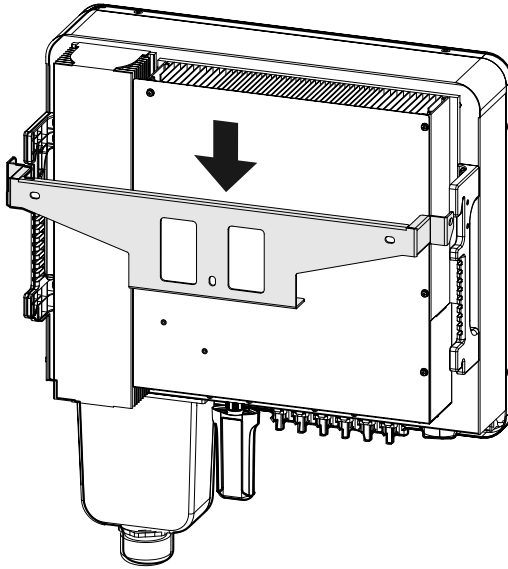

Figure3-11 Hang the inverter to installation holder

Step 6 Fasten the inverter to the installation holder by the equipped stainless steel combination bolt M5*16 and then lock it, as shown in Figure3-12.

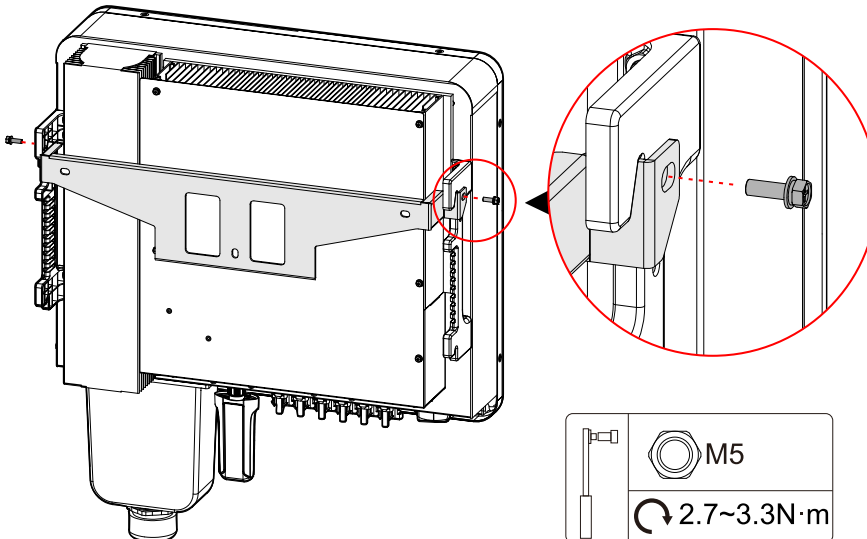

Figure3-12 Fasten the inverter

----End

3.5 Electrical Connection

3.5.1 Wire Requirements

The wiring terminals are located at the bottom of the inverter, as shown in Figure2-5 and Table2-2 .
The recommended wire specification is as shown in Table3-1.

Table3-1 Wire specification

Wire name	Recommended cross-sectional area of wire
PV string input wire	(Rated voltage $\geq 1000\text{V}$) $4\text{ mm}^2 \sim 6\text{ mm}^2$
AC output wire	Outdoor 5-core wire: $16\text{ mm}^2 \sim 35\text{ mm}^2$ (the outer diameter of wire should be less than 38mm.)
COM. communication wire	8-core network wire
Grounding wire	16 mm^2

NOTE

- The wires in above table are based on UL copper wire. If other wires are used, please replace them according to the standard. The wire materials selected by our company have passed the national standard certification or UL certification.
- If the recommended cross-sectional area of wire is not adopted, please confirm with our company.
- If using the aluminum wire, it should adopt copper-aluminum transition terminal.

3.5.2 External Grounding Connection



The grounding connection of the external grounding terminal cannot replace the connection of the PE terminal of AC output wire. Make sure that both of them are grounded reliably.

- Step 1 Strip the insulation layer of the grounding wire by wire stripper,, and crimp it into the equipped round terminal, as shown in Figure3-13.

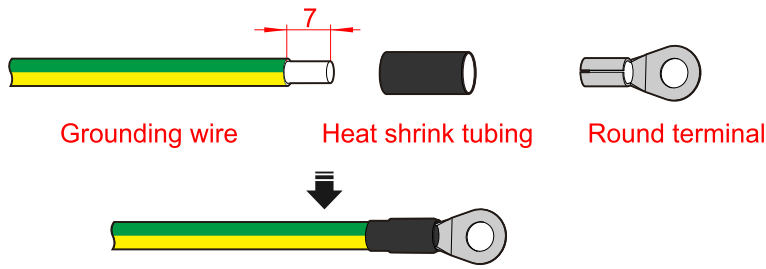

Figure3-13 Crimp the grounding wire (unit: mm)

Step 2 Connect the crimped grounding wire to the external grounding terminal at the side of the inverter by equipped stainless steel combination bolt M5*12, as shown in Figure3-14.

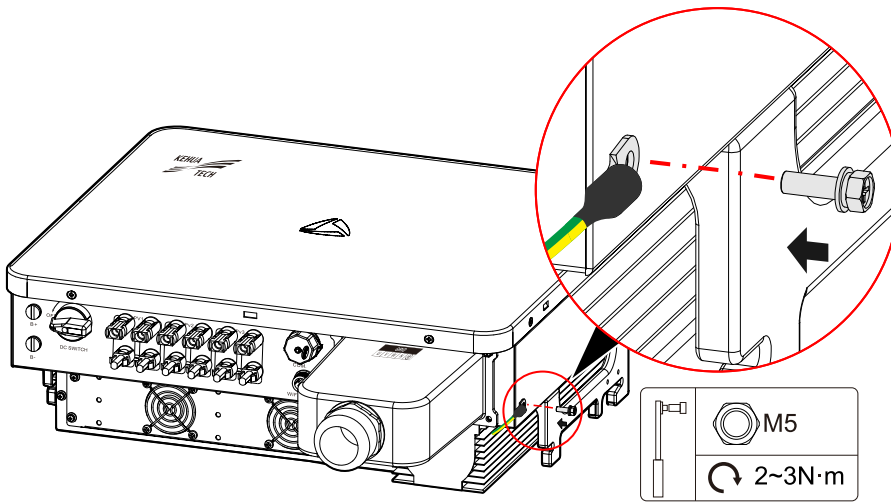

Figure3-14 External grounding connection

NOTE

In order to improve the anti-corrosion performance of the external grounding terminal, it is recommended to paint anti-rust paint on the external grounding terminal after finishing the external grounding connection.

CAUTION

The grounding of inverter mustn't connect with the grounding of the lighting rod of the building where the inverter installs. It should separate them (as shown in Figure3-15), or the lightning stroke will damage inverter.

The grounding of the inverter should be directly connected to the grounding system, and the impedance should be less than 20mΩ.

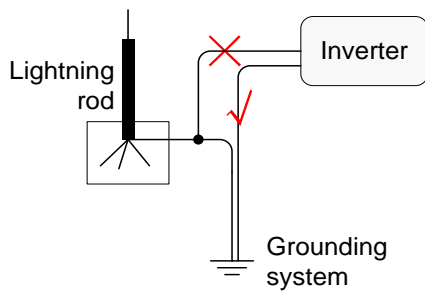

Figure3-15 The grounding of inverter

----End

3.5.3 PV String Input Wiring

CAUTION

When installing, use the equipped DC terminals and PV connectors to avoid inverter damage.

Switch off the DC switch before connecting the PV string.

Ensure that the connection between PV string and inverter at positive pole and negative pole is correct.

The DC input voltage should be less than the max. input voltage of the inverter.

It's forbidden to connect the positive pole or negative pole of PV string with grounding wire, or it will cause inverter damage.

The PV string terminal not connected must take waterproof and shockproof measures.

NOTE

The inverter has three groups of MPPT. The model, quantity, installation angle and direction of the PV strings connected with PV string terminals must be the same. Each MPPT must be connected with PV string.

Use the DC terminals and PV connectors in the accessories for DC input wiring. There are two types of PV connectors: positive connectors and negative connectors, which respectively use positive metal terminals and negative metal terminals. The specific steps are as follows.

- Step 1 Strip the insulation layer of the positive and negative wires for 7mm by wire stripper, as shown in Figure3-16.



Figure3-16 Strip the PV string input wires (unit: mm)

NOTE

It is recommended to use red wires for positive and black wires for negative to avoid wrong connection. If other color wires are used, please confirm the corresponding relationship when crimping each wire to the connector.

- Step 2 Loosen the lock nuts of the positive and negative connectors, draw the positive and negative wires through the corresponding lock nuts, and crimp the positive wire and negative wire to the positive and negative metal terminals respectively, and then check whether the positive and negative wires are crimped firmly, as shown in Figure3-17.

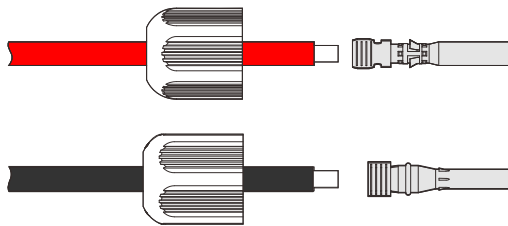

Figure3-17 Crimp the metal terminals

- Step 3 Insert the crimped positive and negative wires into the corresponding insulated shells until you hear a clicking sound, it means the connection is good.

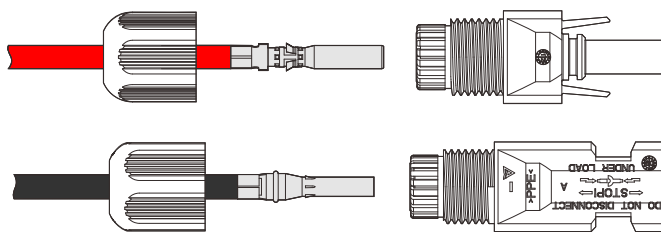

Figure3-18 Fix the metal terminals

- Step 4 Tighten the locking nuts of the positive and negative connectors to corresponding insulating shells, as shown in Figure3-19.

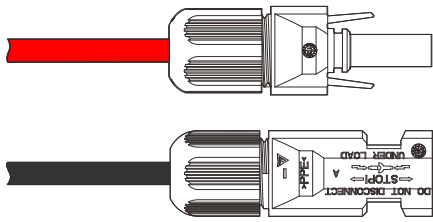

Figure3-19 Tighten the lock nut

- Step 5 Check whether the polarity of the PV string is correct, and ensure that the open-circuit voltage in any case does not exceed the max. input voltage of the inverter.

CAUTION

The three groups of PV strings in PV side have been parallel connected in the inner of the inverter. Do not reverse connect the PV string, or it will cause the PV string or inverter damage permanently.

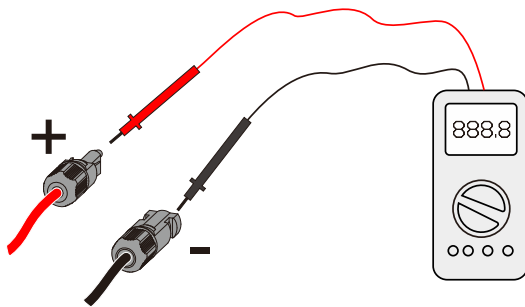

Figure3-20 Measuring the open-circuit voltage

- Step 6 Insert the positive and negative connectors into the PV "+" and "-" terminals at the bottom of the inverter respectively (as shown in Figure3-21). When you hear a click, it means the connection is good (as shown in Figure3-22) .

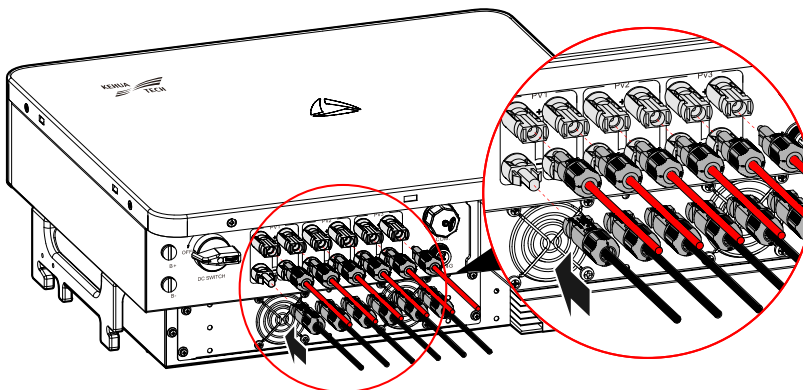

Figure3-21 Connect PV connectors

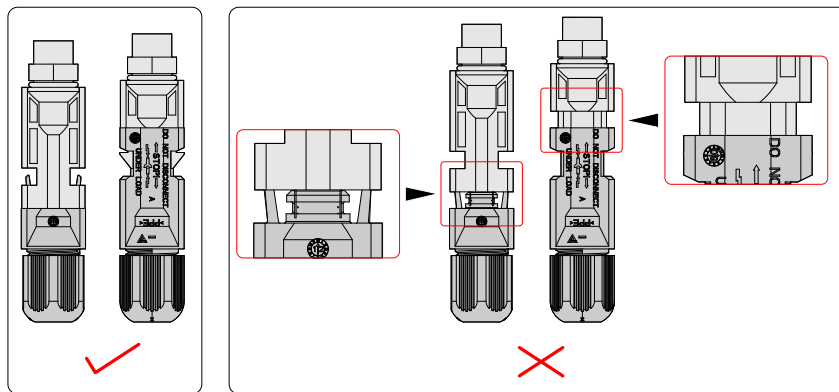

Figure3-22 PV connector installation method

----End

3.5.4 AC Output Wiring

! CAUTION

It's forbidden that several inverters share an AC switch.

It's forbidden to connect with load between inverter and the AC switch.

To ensure the inverter can be disconnected with load safely, we suggest equipping an independent tripolar or quadrupole switch for each inverter to protect the inverter. Before connecting with grid, ensure that the grid parameters are all in the allowable range of the inverter.

Table3-2 Recommended AC switch specification

Model	Specification
SPI30K-B X2	100A
SPI33K-B X2	100A
SPI36K-B X2	100A
SPI36K-B X2P	100A
SPI40K-B X2	100A
SPI40K-B X2P	100A

⚠ CAUTION

During wiring, please pay attention to distinguish the AC live wire, neutral wire and grounding wire.

- Step 1 Strip the external insulation layer of AC wire for about 100mm, strip the inner lead insulation layer for about 15mm, as shown in Figure3-23.

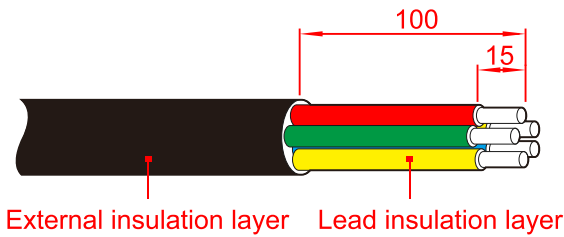

Figure3-23 Strip the AC output wire (unit: mm)

📖 NOTE

If the wire is hard, comparing with wire U and PE, strip the wire V, W and N less than 5mm so that the wire U and PE can be easily installed to the wiring terminal (the wire color of yellow, green, red, blue and yellow-green stands for wire U, V, W, N and PE respectively. If using the other color wires, please confirm the corresponding connection relationship.).

- Step 2 Draw the AC output wire through the AC output waterproof cover, crimp them to the DT/OT terminals, and then fasten them to corresponding wiring terminal by screwdriver, as shown in Figure3-24.

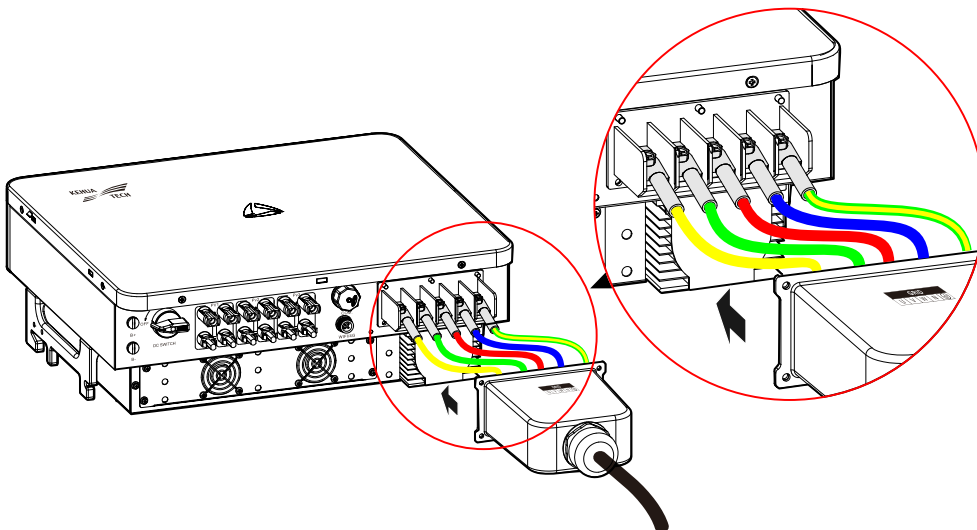

Figure3-24 Connect the AC output wire

- Step 3 After wiring, fasten the AC output waterproof cover to the inverter by equipped four stainless steel combination bolt M5*12 and then fasten the external AC output nut, as shown in Figure3-25.

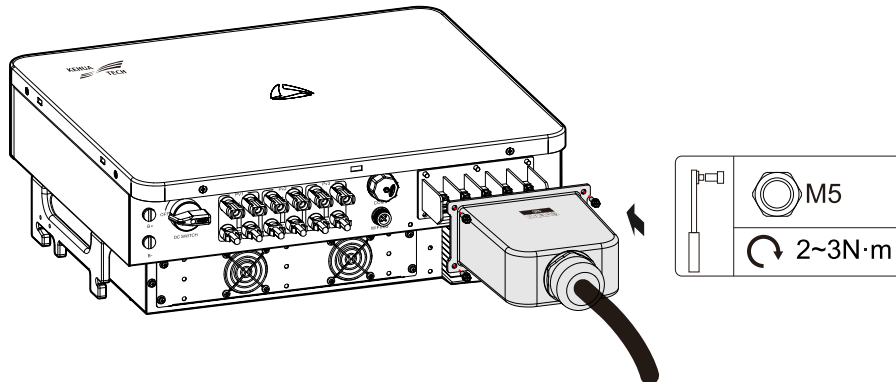

Figure3-25 Fasten the AC output waterproof cover

CAUTION

When several inverters are parallel connected, it needs to equip the switch with impact tripping function at the rear end of the AC output of the inverter.

----End

3.5.5 WIFI/4G Communication Connection

Insert the WIFI (optional) /4G stick it to the WIFI/4G interface (as shown in Figure3-26) , user can monitor the inverter running information through WiseSolar+ APP or "Energy Cloud" to realize the internet monitoring, the monitoring scheme is as shown in Figure3-27.

NOTE

When installing the WIFI/4G stick, pay attention to the limiting position, and don't wrongly insert it. When tightening, do not use excessive force, so as not to damage the interface.

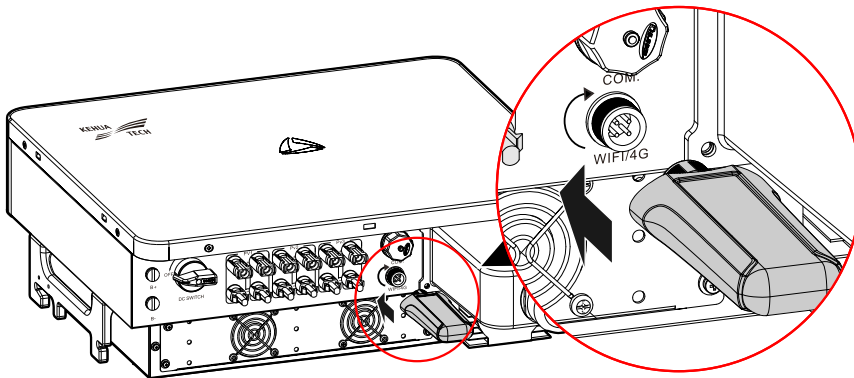

Figure3-26 WIFI/4G communication connection

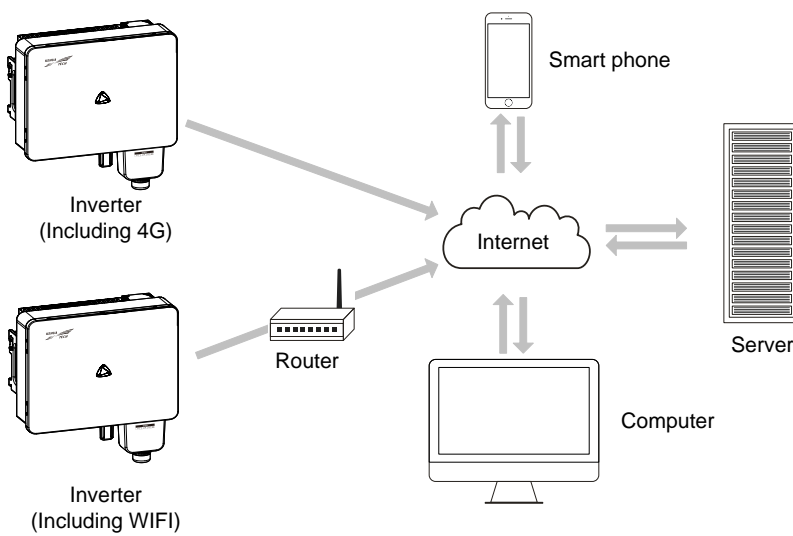

Figure3-27 WIFI/4G monitoring scheme

NOTE

WiseSolar+APP can communicate with inverter through WIFI/4G stick to realize the local and remote maintenance. User can perform the information query, alarm query, event query, parameter setting, etc. of inverter through WiseSolar+ APP.

Download and install WiseSolar+APP:

- Method 1: search WiseSolar+ and download the WiseSolar+ APP through the following application market, and install the WiseSolar+ APP.
 1. Application market (Android Chinese user) ;
 2. APP store (iOS) .
- Method 2: scan the QR code below to download and install the WiseSolar+ APP according to prompting.



----End

3.5.6 COM. Communication Connection (Optional)

COM. interface can be set to DRM and RS485 communication interface, they all adopt RJ45 plug to connect. The pin definition of RJ45 plug is as shown in Figure3-28.

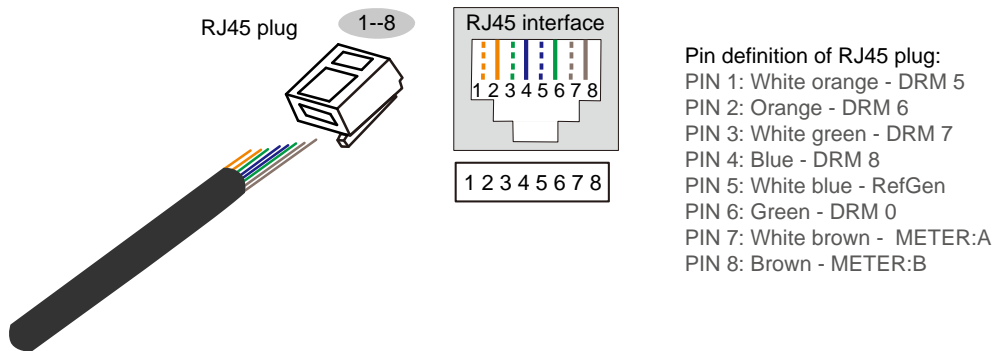

Figure3-28 Pin definition of inverter's RJ45 plug

DRM interface

DRM interface is used to connect with the DRM controlling device.



When the COM. interface set to DRM interface, the PIN7 and PIN8 of inverter's RJ45 plug cannot connect wires. The PIN7 and PIN8 of external DRM adapter's RJ45 plug must be short connected together.

RS485 interface

RS485 interface is used to communicate with smart meter to achieve anti-backflow function. The connection between smart meter and inverter and grid is as shown in Figure3-29.

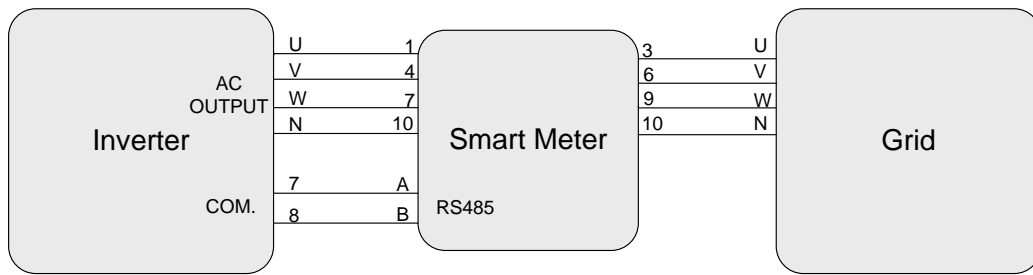

Figure3-29 Connection diagram between smart meter and inverter and grid

NOTE

When using the anti-backflow function, the following setting must be done:

1. Set the anti-backflow setting in “System Setting-General Setting-I/O switch” to ON through WiseSolar+;
2. Set the anti-backflow power in “System Setting-General Setting-Engineer set” according to the actual use (the setting value of anti-backflow power is percentage, it is corrected by rated power. For example, when the rated power of the inverter is 10kW, if the anti-backflow power is set to 30%, the set anti-backflow power is 3kW).
3. The pin illustration of smart meter is as shown in Table3-3, detail installation please see the instruction manual.

Table3-3 Pin illustration of smart meter

Pin	Illustration
1	Connect to AC OUTPUT phase-U of the inverter.
3	Connect to grid phase-U.
4	Connect to AC OUTPUT phase-V of the inverter.
6	Connect to grid phase-V.
7	Connect to AC OUTPUT phase-W of the inverter.
9	Connect to grid phase-W.
10	Connect to AC OUTPUT phase-N of the inverter and phase-N of grid.
RS485: A	Connect to pin7 of the waterproof RJ45 connector.
RS485: B	Connect to pin8 of the waterproof RJ45 connector.

Connection procedure

The connection of COM. interface is as follows.

Step 1 Strip the insulation layer of communication wire by wire stripper, loosen the lock nut of waterproof RJ45 connector and then draw the communication wire through the RJ45 connector and crimp it to the RJ45 plug, as shown in Figure3-30.

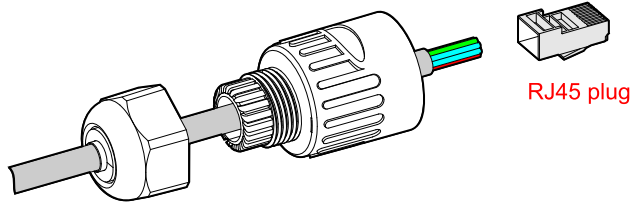

Figure3-30 Crimp the wires of RJ45 plug

Step 2 After crimping, insert the RJ45 plug into the buckle (as shown in Figure3-31), and then fasten the lock nut.

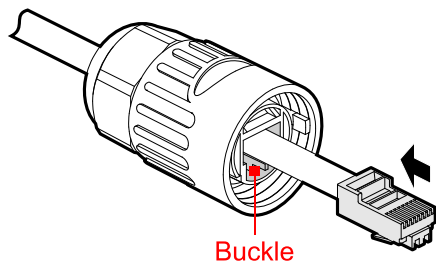

Figure3-31 Buckle position

Step 3 Loosen the waterproof cover on the COM. interface, insert the RJ45 connector to the COM. interface (as shown in Figure3-32) and fasten it.

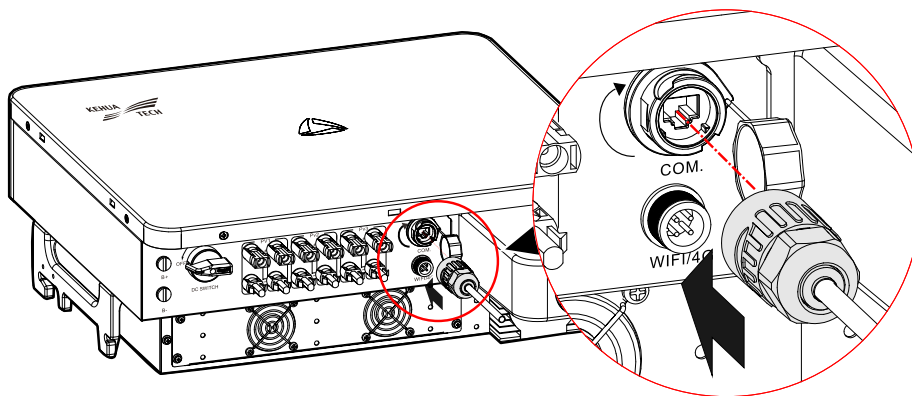

Figure3-32 Install the COM. interface

----End

3.6 Check the Installation

After finishing the installation, check the following items:

- Check if the PV string input wire, AC output wire and communication wire are connected rightly.
- Check if the inverter is installed firmly.
- Check if all the screws on the surface of the inverter are tightened.

4 Startup and Shutdown

This chapter mainly introduces how to start and shut down the inverter.

4.1 Check Before Startup

Before starting inverter at the first time, please check the following items.

- Ensure that the inverter is properly installed and fastened.
- Ensure that the DC switches and external AC switches are all in the OFF position.
- Ensure that the polarity of PV strings are correct.
- Ensure that all wires are fastened and the insulation layer of wires are good.
- Ensure the gap between the nylon cable gland and wires and the unconnected connectors are sealed well.
- Ensure that the grid voltage meets the AC voltage requirement of the inverter.
- Ensure that the cross-sectional area of the input wire meets the max. load current of inverter.
- Ensure the wiring holes of inverter are blocked by fireproofing mud.
- Ensure that the distance among AC terminals meets the requirements of safety standard.
- Ensure that the input voltage of each PV string is same.

4.2 Start Inverter



Damaged device or device fault may cause electric shock or fire!

- Before operation, please check if the inverter is damaged or has other danger.
 - Check if the external device or circuit connection is safe.
-

- Step 1 Switch on the DC switches on the inverter and the project site. When the PV string provides enough startup voltage, the inverter will start and the indicator will be on.
- Step 2 Switch on the AC switch between inverter and grid, if the indicator is not red, that is there is no fault.
- Step 3 When the DC and AC power are all normal, the inverter will prepare to start grid-tied. Check the inverter parameters and the grid parameters, if they are in the normal range, a moment later, the inverter will perform the insulation impedance detection.
- Step 4 A moment later, the inverter will generate power normally.

----End

4.3 Shut Down Inverter



When the inverter works normally, do not switch off the DC switches and AC switch with load to avoid switch damage for arc. At worst, the inverter may be damaged.

- Step 1 Switch off the DC switches on the inverter and project site, a moment later, the indicator will be off.
- Step 2 Disconnect the connection between the inverter and grid.

----End

5 Maintenance and Troubleshooting

This chapter mainly introduces the maintenance and troubleshooting.

5.1 Maintenance

5.1.1 Inverter Maintenance



Do not perform the maintenance until the inverter is powered off for 20 minutes and all power sources are disconnected.

The inverter needn't to be maintained regularly, but the sundries or dust may influence the heat dissipation performance, so, use soft brush to clean the inverter. If the LED indicator surface is too dirty to read, use a wet cloth to clean them when the inverter is powered off. When the indicator surface is dry, it can start inverter.



During running, do not touch the inverter. The temperature of some parts on the inverter is too high, and may cause scald injury. After shut down the inverter and wait until it cooling down, then do the maintenance and clean.



Do not clean the inverter with any solvent, abrasive material or corrosive material.

5.1.2 Fan Maintenance

The inverter has build-in fans to cool during operation. If the fan does not work properly, then the inverter does not cool effectively, that the inverter's efficiency may be affected or cause derating. Therefore, it is necessary to keep the fan clean and replace the damaged fan in time. The cleaning and replacement steps of the fan are as follows:

- Step 1 Disconnect the AC switch.
- Step 2 Rotate the DC switch to the "OFF" position and disconnect all PV string input.
- Step 3 Wait at least 20 minutes.
- Step 4 Disconnect all electrical connections.
- Step 5 Dismantle the cover plate, as shown in Figure5-1.

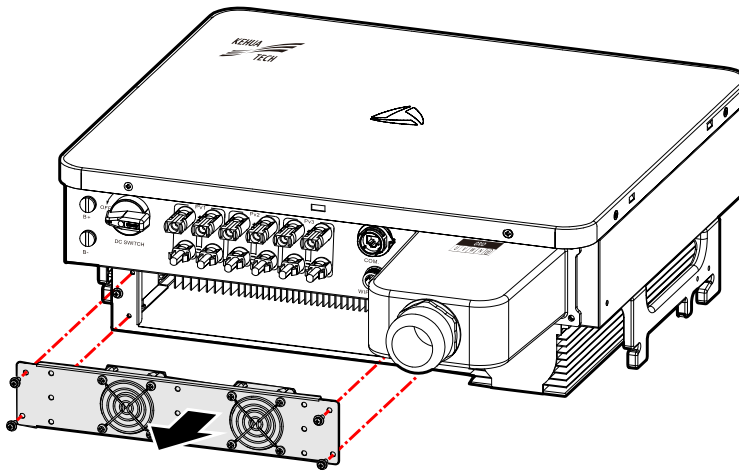

Figure5-1 Dismantle the cover plate

- Step 6 Disconnect the connector connected with fan, as shown in Figure5-2.

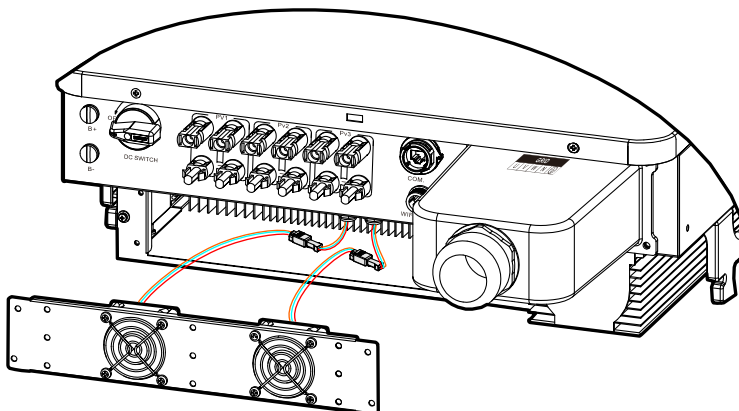

Figure5-2 Disconnect the connector

Step 7 Loosen the screws that fixed the fan and take out fans, as shown in Figure5-3.

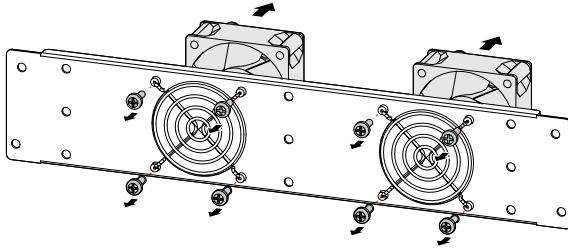

Figure5-3 Dismantle fan

Step 8 Clean the fan with a soft brush or vacuum cleaner; Or replace the damaged fan (wind direction: up).

Step 9 After maintenance, install the fan in reverse order. Restart the inverter.

NOTE

The fan maintenance only can be performed by professional.

----End

5.2 Troubleshooting

The inverter is designed on the basis of the grid-tied operation standards and meets the requirements of safety and EMC. Before provided to client, the inverter has been experienced for several rigorous tests to ensure reliable and optimizing operation.

If some faults occur, the indicator will show fault. Under the circumstances, the inverter may stop power generation. The troubleshooting is as shown in Table5-1.

Table5-1 Troubleshooting list

No.	Fault information	Solution
1	Grid voltage abnormal	Check whether the safety regulations of the inverter meet the requirements of the local grid connection and check the voltage of the local power grid. If the above is normal, please contact your local agency or service center.
2	Grid frequency abnormal	Check whether the safety regulations of the inverter meet the requirements of the local grid connection and check the frequency of the local power grid. If the above is normal, please contact your local agency or service center.

No.	Fault information	Solution
3	Output over-current	If the fault exists, please contact your local agency or service center.
4	Output current DC component abnormal	If the fault exists, please contact your local agency or service center.
5	Residual current abnormal	Check the insulation resistance of the positive and negative poles of the PV string to the ground; check whether the environment around the inverter is dry; check the grounding of the inverter. If the above is normal, please contact your local agency or service center.
6	Relay fault	If the fault exists, please contact your local agency or service center.
7	Radiator over-temperature	Check whether the radiator of the inverter is blocked, and check whether the ambient temperature of the inverter is too high or too low. If the above is normal and the fault still exists, please contact your local agency or service center.
8	Insulation impedance abnormal	Check the insulation resistance of the positive and negative poles of the PV string to the ground; check whether the environment around the inverter is dry; check whether the grounding point inside the inverter is loose. If the above is normal, please contact your local agency or service center.
9	Fan abnormal	If the fault exists, please contact your local agency or service center.
10	Inner over-temperature	Check whether the radiator of the inverter is blocked, and check whether the ambient temperature of the inverter is too high or too low. If the above is normal and the fault still exists, please contact your local agency or service center.
11	MPPT x over-voltage	Check the system PV string configuration, if the above is normal, please contact your local agency or service center.
12	MPPT x over-current	If the fault exists, please contact your local agency or service center.
13	Branch x over-current	Check the system PV string configuration, if the above is normal, please contact your local agency or service center.
14	Branch x reverse connected	Check whether the branch x is connected in reverse, if the above is normal, please contact your local agency or service center.

No.	Fault information	Solution
15	Inner abnormal	If the fault exists, please contact your local agency or service center.

CAUTION

If the inverter has an alarm mentioned in Table5-1, please shut down inverter (refer to **4.3 Shut Down Inverter**), 20minutes later, restart the inverter (refer to **4.2 Start Inverter**). If the alarm status is not removed, please contact our local agency or service center. Before contacting us, please prepare the following information.

1. Inverter S/N.
 2. Distributor/ dealer of the inverter (if has).
 3. The date of grid-tied power generation.
 4. Problem description.
 5. Your detail contact information.
-

6 Stop Running, Dismantle, Discard Inverter

This chapter introduces the dispose way for stop running, dismantling, discarding the inverter.

6.1 Stop Running

Normally, the inverter don't need to be shut down, but when maintenance, it is necessary to shut down the inverter.



Please disconnect the AC and DC connection of inverter according to following procedures successively, or, it may cause human injury or device damage.

- Step 1 Disconnect the external AC switch, and set warning marks at disconnected site to avoid improperly switching on and even cause accident.
- Step 2 Switch off the DC switches on the inverter.
- Step 3 Wait for 20mins at least, ensure that the inner capacitor discharges completely.
- Step 4 Loosen the locked part of PV connectors by MC4 wrench, and take down the PV connectors.
- Step 5 Dismantle the AC output waterproof cover, measure the wires and ensure that there is no electricity in the AC wires, and then dismantle the AC wires and communication wires.
- Step 6 Install MC4 waterproof plug and AC output waterproof cover.

----**End**

6.2 Dismantle the Inverter



After the connection among inverter and grid and PV string is completely disconnected and wait for 20mins at least, ensure that the inner capacitor discharge completely and check that there is no voltage and current in the inverter by the detection equipment, and then the inverter can be dismantled.

- Step 1 Disconnect all connection successively in reversed procedures of **3.5 Electrical Connection**.
- Step 2 Dismantle the inverter in reversed procedures of **3.4 Inverter Installation**.
- Step 3 If the inverter will be installed and used in the future, please dismantle the installation holder on the wall or bracket, then pack and store the inverter properly. (see **7.1 Package** and **7.3 Storage**).

----End

6.3 Discard the Inverter

For the inverter that will not to be used, user needs to discard the inverter according to related provision.



The battery, module and other components inside the inverter may pollute the environment, please do corresponding dispose on the basis of related provision.

7 Package, Transportation, Storage

This chapter mainly introduces the package, transportation and storage.

7.1 Package

The package of product is carton. When packing, pay attention to the placing direction requirements. One side of carton, it should print warning icons, including keep dry, handle with care, up, stacking layer limit, etc. The other side of carton, it should print the device model, etc. Print the logo of Kehua company and device name on the front of carton.

7.2 Transportation

Pay attention to the warnings on the carton. Don't impact severely when transportation. In case of damaging device, it should follow the placing direction that shows on the carton. Don't carry device with the objects that inflammable, explosive, or corrosive. Don't put device in the open-air warehouse when transshipment. Leaching and mechanical damage by rain, snow or liquid objects is prohibited.

7.3 Storage

When storing device, it should follow the placing direction that shows on the carton. The gap is 20cm between the carton and ground and the clearance is at least 50cm from carton to wall, heat source, cold source, windows or air inlet.

The storage environment temperature is $-40^{\circ}\text{C} \sim 70^{\circ}\text{C}$. If storing or transporting device beyond the working temperature, before startup, set it alone and wait for the temperature reaches to the range of the working temperature and keep the status more than four hours. In warehouse, It's prohibited that there has poisonous gas, objects that inflammable and explosive, corrosive chemical objects. Besides, it shouldn't have too strong mechanical shaking, impact and strong magnetic field. Under the storage conditions above, the storage period is six months. If it is beyond six months, it has to recheck..

A Technical Specifications

Item \ Model	SPI30K-B X2	SPI33K-B X2	SPI36K-B X2	SPI36K-B X2P	SPI40K-B X2	SPI40K-B X2P
DC input						
Max. input power (kW)	40.5	44.55	48.6	48.6	54	54
Max. input voltage (V)	1100					
MPPT voltage range (V)	180-1100					
MPPT voltage with full load (V)	350-850	400-850	450-850	450-850	500-850	500-850
Startup voltage (V)	150					
No. of MPPTs	3					
Strings per MPPT	2/2/2	2/2/2	2/2/2	2/2/2	2/2/2	2/2/2
Max. input current (A)	30*3	30*3	30*3	40+20+20	30*3	40+20+20
AC output						
Rated output power (kW)	30	33	36	36	40	40
Max. output power (kW/kVA)	33	36.3	39.6	39.6	44	44
Rated grid voltage (Vac)	400					
Grid voltage range (V)	320-480					
Grid type	3W+N+PE					
Rated output current (A)	43.3	47.6	52.0	52.0	57.7	57.7
Max. output current (A)	47.6	52.4	57.2	57.2	63.5	63.5

Item	Model	SPI30K-B	SPI33K-B	SPI36K-B	SPI36K-B	SPI40K-B	SPI40K-B
		X2	X2	X2	X2P	X2	X2P
Rated grid frequency (Hz)	50/60						
Grid frequency range (Hz)	45-55/55-65						
Power factor (rated power)	>0.99						
Power factor adjusting range	0.8 ahead ~0.8 lag (0.8* rated power)						
Output harmonic content (rated condition)	<3% (test on rated power) <5% (load is 50% rated power)						
DC component	<0.5%I _n						
Efficiency							
Max. efficiency	98.6%						
Europe efficiency	98.2%						
Protection							
DC reverse connection protection	Yes						
Islanding protection	<2s						
AC short-circuit protection	Yes						
Residual current protection	Yes						
DC switch	Yes						
Input DC impedance monitor	Yes						
Surge protection	Varistor						
Over-voltage grade	DC II/AC III						
Size (W×D×H) (mm)	550*480*200						
Weight (kg)	27						
Installation method	Wall-mounting						
Isolation method	No transformer						

Item	Model	SPI30K-B	SPI33K-B	SPI36K-B	SPI36K-B	SPI40K-B	SPI40K-B
		X2	X2	X2	X2P	X2	X2P
Degree of protection	IP66						
Self-consumption at night	<1W						
Operating temperature range	-35~60℃ (>40℃ derating)						
Relative humidity	0~100%, without condensation						
Cooling method	Smart-cooling						
Operating altitude	4000m (>3000m derating)						
Noise	<50dB@ 1m						
Display	LED						
Communication method	RS485, WIFI (optional) ,4G, smart meter (optional), anti-backflow (optional)						
AC terminal	Wiring terminal bars						
DC terminal	MC4 (4 mm ² ~6 mm ²)						
Other function							
Whole machine	Update online						

- Specifications are subject to change without prior notice.

B Acronyms and Abbreviations

A

AC Alternating Current

D

DC Direct Current

L

LCD Liquid Crystal Display

LED Light-emitting Diode

M

MPPT Maximum Power Point Tracking

P

PE Protective Earthing

PV Photovoltaic

R

RS485 Recommend Standard485



XIAMEN KEHUA DIGITAL ENERGY TECH CO., LTD.

ADD: No. 457, Malong Road, Torch High-Tech Industrial
Zone, Xiamen, Fujian, China (361000)

TEL: 0592-5160516 (8 lines)

FAX: 0592-5162166

[Http://www.kehua.com](http://www.kehua.com)



Technical Support

4402-04049 002