

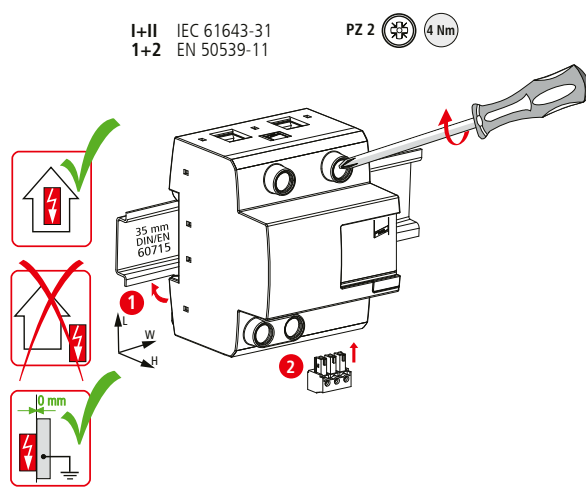

DEHNcombo DCB YPV ... (FM)

- DE Einbauanleitung
- GB Installation instructions
- IT Istruzioni di montaggio
- FR Instructions de montage
- NL Montagehandleiding
- ES Instrucciones de montaje
- PT Instruções de montagem
- DK Monteringsvejledning
- SE Monteringsanvisning
- FI Asennusohje
- GR Οδηγίες συναρμολόγησης
- PL Instrukcja montażu
- CZ Montážní návod
- TR Kurulum Talimatları
- RU Инструкция по монтажу
- CN 安装说明
- HU Szerelési útmutató
- JP 設置説明書



	DCB YPV 1200 (FM)	DCB YPV1500 (FM)
$U_{CPV} (DC+ \rightarrow DC-)$	$\leq 1200 \text{ V DC}$	$\leq 1500 \text{ V DC}$
$U_{CPV} (DC+/DC- \rightarrow PE)$	$\leq 1200 \text{ V DC}$	$\leq 1500 \text{ V DC}$
I_{total}	12.5 kA (10/350 μ s)	
I_{imp}	6.25 kA (10/350 μ s)	
I_n	20 kA (8/20 μ s)	
I_{max}	40 kA (8/20 μ s)	
I_{SCPV}	10 kA	
$I_{PE, DC}$	$\leq 100 \mu\text{A}$	
θ°	-40°C ... +80°C	
ϕ	5% ... 95%	
IP 1)	20	
failure behavior	open circuit	
Ausfallverhalten	Abtrennung	
L x W x H	72 mm x 90 mm x 73 mm	

min. □ DC+ / -, DC- / +, ⊥	1.5 mm ²	
max. □ DC+ / -, DC- / +, ⊥	25 mm ²	35 mm ²

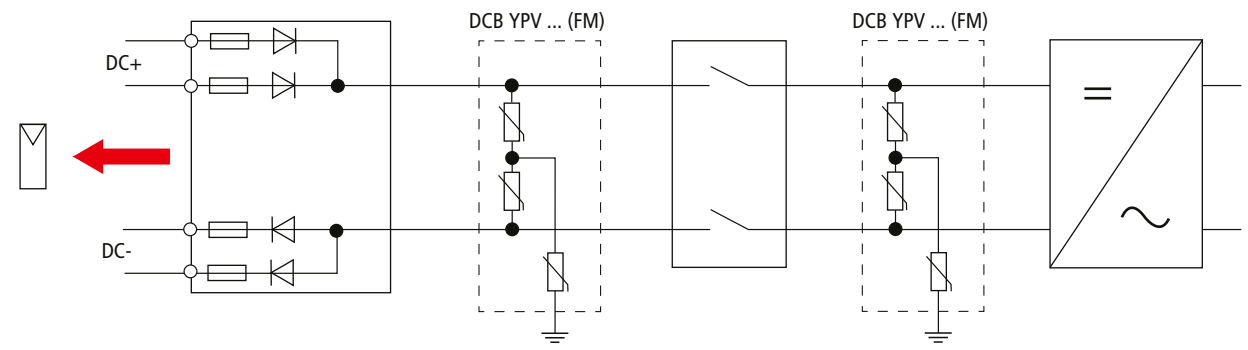

DCB YPV 1200 (FM)

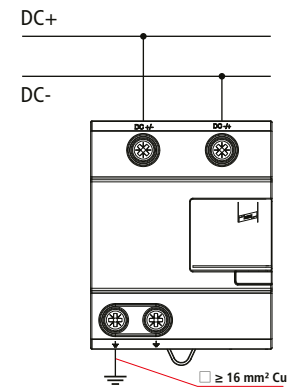

DCB YPV 1500 (FM)

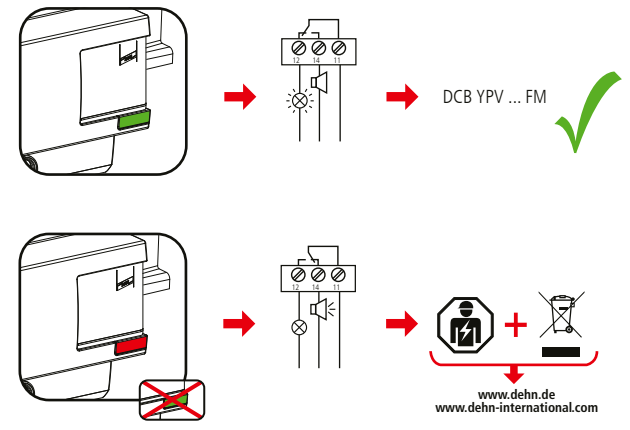
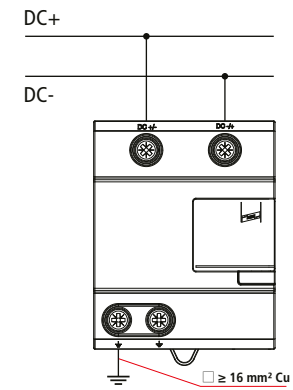

DCB YPV ... FM	
U_N / I_N	AC: 250 V / 0.5 A
	DC: 250 V / 0.1 A 125 V / 0.2 A 75 V / 0.5 A
max. 1.5 mm ²	

www.dehn.de
www.dehn-international.com

