

1500V Three-phase On-grid String Inverter

SPI250K-B-H Series



Product Features

High efficient

- Advanced three-level technology max. efficiency 99.02%
- 12 MPPT design, Compatible with bifacial PV panel
- Anti-PID and PID recovery function

System optimization

- DC 2 in 1 connection enabled and compatible with AL AC cables
- Support PLC communication, save cable investment
- Support night SVG and quick response

Safe and reliable

- IP66 and C5 anti-corrosion grade, intelligent fan with IP68 protection
- Redundant power supply by AC and DC
- Built-in AC/DC SPD protection

Intelligent management

- Intelligent I-V and fault wave recording, quick failure analysis
- Smart online upgrade, easy for system maintenance
- Capacitor detection and life prediction reduce the failure risk

Function Diagram

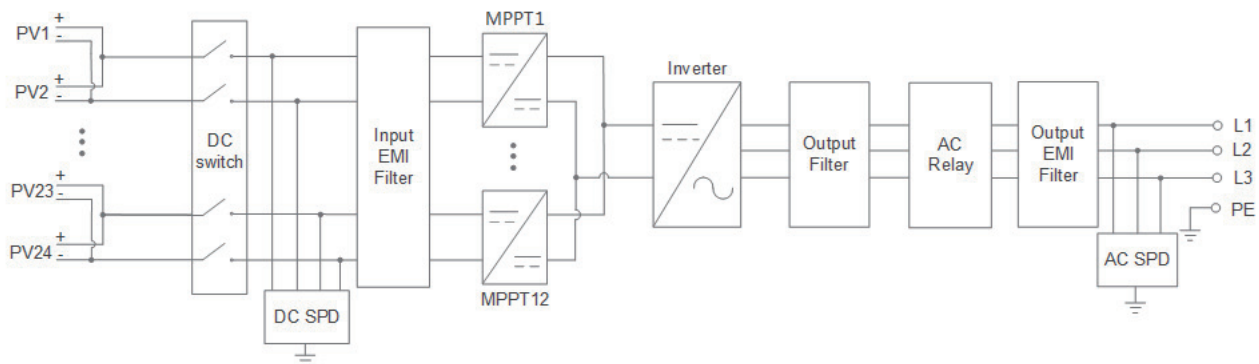

Technical Specification

Items	SPI250K-B-H
DC Input (PV)	
Max. PV input voltage	1500Vdc
Rated input voltage	1050Vdc
Max. PV input current	12×30A
No. of MPPTs	12
No.of PV strings per MPPT	2
MPPT voltage range	500~1500Vdc
Starting voltage	500Vdc
DC switch	Yes
AC Output (On-grid)	
Rated AC output power	250kW@30°C, 235kW@40°C, 220kW@50°C
Max. output power	250kW
Rated AC output voltage	800Vac
Rated output current	180.4A
Max. output current	198.4A
Rated grid frequency	50Hz/60Hz
Grid frequency range	45~55Hz/55~65Hz
Power factor	>0.99 (rated power)
Adjustable power factor	0.8 (leading)~0.8 (lagging)
THDi	<3% (rated power)
Efficiency	
Max. efficiency	99.02%
European efficiency	98.80%
MPPT efficiency	99.90%
Function and protection	
Anti-islanding	Yes
DC (PV) reversed connection	Yes
AC short circuit protection	Yes
Temperature protection	Yes
Surge protection	DC Type II & AC Type II
AFCI function	Yes (optional)
Integrated PID function	Yes (optional)
IV curve scan and diagnosis	Yes (optional)
Support night SVG function	Yes (optional)
General	
Dimensions (W×H×D)	1100×760×361mm
Weight	99kg
IP grade	IP66
Self-consumption at night	<2W
Cooling type	Intelligent forced air cooling
Altitude	4000m (>3000m derating)
Operating temperature	-35~60°C
Relative humidity	0~100%
Display	LED+APP
DC terminal	MC4 Terminal
AC terminal	OT Terminal
Installation method	Wall-mounted
Communication	RS485, PLC (optional), WIFI(optional)/GPRS (optional)
Certification	IEC/EN62109-1, IEC/EN62109-2, EN61000, IEC61683, EN50530, IEC62116, IEC61727, IEC60529, BDEW, VDE0126-1-1, CEI0-16, EN50549-1, EN50549-2

- Specifications are subject to change without prior notice.

Kehua Digital Energy

Add: No. 457, Malong Road, Torch High-Tech Industrial Zone, Xiamen Fujian China

Tel: +86-592-5160516 Fax: +86-592-5162166 www.kehua.com

