

---

DTSU666 Three-phase Smart Meter

# User Manual

ZTY0.464.1416

Zhejiang Chint Instrument & Meter Co., Ltd.

March , 2021

## Catalog

1. Brief Introduction .....	2
2. Working Principle.....	3
3. Main Technical Performance & Parameters .....	4
4. Main function.....	6
5. Outline and installation size.....	14
6. Installation and operation manual.....	15
7. Diagnosis, analysis and elimination for common faults .....	17
8. Transportation & Storage.....	18
9. Maintenance & Service.....	18

DTSU666 three phase Smart meter (Din-rail)	ZTY0.464.1416
Operation manual	Page 2, Total 20

## 1. Brief Introduction

### 1.1. Main application & applicable range

DTSU666 three phase Smart meter (Din-rail) (hereinafter referred to as the “instrument”) is designed based on power monitoring and energy metering demands for electric power system, communication industry, construction industry, etc. as a new generation of intelligent instrument combining measurement and communication function, mainly applied into the measurement and display for the electric parameters in the electric circuit including three voltage, three current, active power, reactive power, frequency, positive& negative energy, four-quadrant energy, etc. Adopting the standard DIN35mm din rail mounting and modular design, it is characterized with small volume, easy installation and easy networking, widely applied into the internal energy monitoring and assessment for industrial and mining enterprises, hotels, schools, large public buildings.

Complied standards:

IEC 61010-1:2010 《Safety requirements for electrical equipment for measurement, control and laboratory use Part1:General requirements》

IEC 61326-1:2013 《Electrical equipment for measurement, control and laboratory use –EMC requirements Part1:General requirements》

MODBUS-RTU protocol.

### 1.2. Product Features

1) Characterized with positive and reverse active power, combined active power, combined reactive power, four quadrant reactive power metering and storage function with combination mode character can be set.

2) RS485 communication interface, easy to exchange data with outside;

3) Adopting the standard DIN35mm din rail mounting and modular design, it is characterized with small volume, easy installation and easy networking.

### 1.3. Model composition and significance

DTSU666 three phase Smart meter (Din-rail)	ZTY0.464.1416
Operation manual	Page 3, Total 20

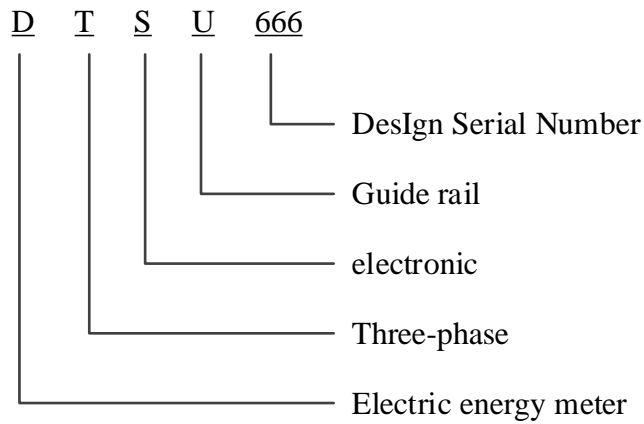

1.4. Temperature range

Operating temperature range:  $-25^{\circ}\text{C} \sim +70^{\circ}\text{C}$  ;

Relative humidity(Annually average):  $<75\%$  non-condensing;

Atmospheric pressure:  $63.0\text{kPa} \sim 106.0\text{kPa}$ ( altitude 4km and below), excepting the requirements for special orders.

2. Working Principle

2.1. Working Principle

The instrument are composed of high accurately integrated circuit specially for measurement (ASIC) and managing MCU, memory chip, RS485 communication module, etc.

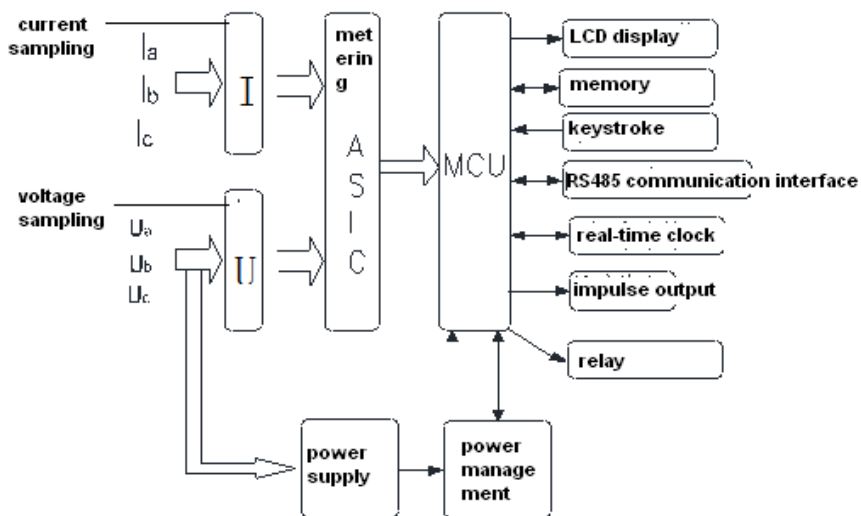

Figure 1 Working principle block diagram

2.2. Principle for the main function module

DTSU666 three phase Smart meter (Din-rail)	ZTY0.464.1416
Operation manual	Page 4, Total 20

The special metering integrated circuit (ASIC) integrated six load two order  $\Sigma$ - $\Delta$  type of A/D conversion, please take the digital signal processing measured by the voltage circuit as well as all the power, energy, effective values, power factor and frequency. This metering chip can measure the active power, reactive power, apparent power, active energy, reactive power, apparent energy of each phase and combined phase, and at the same time measuring current, voltage effective values, power factor, phase angle, frequency and other parameters, entirely satisfying the needs of power meter. The chip provides an SPI interface, convenient for metering parameters as well as parameter calibration between the management MCU.

### 3. Main Technical Performance & Parameters

\*Note: in order to prevail in kind

#### 3.1. types and specifications

Model No.	Accuracy grade	Referenced voltage	Current specification	constant	type
DTSU666	Active power 1	3*230 /400V	100A/40mA	400imp/kWh	Transformer access

\*Note: in order to prevail in kind

#### 3.2. limit of error caused by the current augment

Table 1 The limit value of the active percentage error of meters on balanced load

Meters for	Value of current	Power factor	Percentage error limits for meters of class		
			Class C	Class B	Class A
Connection through current transformers	$0.01I_n \leq I < 0.05I_n$	1	$\pm 1.0$	$\pm 1.5$	$\pm 2.0$
	$0.05I_n \leq I \leq I_{max}$	1	$\pm 0.5$	$\pm 1.0$	$\pm 1.2$
	$0.02I_n \leq I < 0.1I_n$	0.5L、0.8C	$\pm 1.0$	$\pm 1.5$	$\pm 2.0$
	$0.1I_n \leq I \leq I_{max}$	0.5L、0.8C	$\pm 1.0$	$\pm 1.0$	$\pm 1.2$
Direct connection	$0.05I_b \leq I < 0.1I_b$	1	-	$\pm 1.5$	$\pm 2.0$
	$0.1I_b \leq I \leq I_{max}$	1	-	$\pm 1.0$	$\pm 1.2$
	$0.01I_b \leq I < 0.2I_b$	0.5L、0.8C	-	$\pm 1.5$	$\pm 2.0$

DTSU666 three phase Smart meter (Din-rail)	ZTY0.464.1416
Operation manual	Page 5, Total 20

	$0.2I_b \leq I \leq I_{max}$	0.5L、0.8C	-	$\pm 1.0$	$\pm 1.2$
Note	$I_n$ : secondary rated current of the current transformer; $I_b$ : calibrated current of the meter; L: inductive; C: capacitive;				

Table 2 The limit value of the reactive percentage error of meters on balanced load

Value of current		$\sin\phi$ (inductive or capacitive )	Percentage error limits for meters of class
Direct connection	Connection through current transformers		Class A
$0.05I_b \leq I < 0.1I_b$	$0.02I_n \leq I < 0.05I_n$	1	$\pm 2.5$
$0.1I_b \leq I \leq I_{max}$	$0.05I_n \leq I \leq I_{max}$	1	$\pm 2.0$
$0.1I_b \leq I < 0.2I_b$	$0.05I_n \leq I < 0.1I_n$	0.5	$\pm 2.5$
$0.2I_b \leq I \leq I_{max}$	$0.1I_n \leq I \leq I_{max}$	0.5	$\pm 2.0$
$0.2I_b \leq I \leq I_{max}$	$0.1I_n \leq I \leq I_{max}$	0.25	$\pm 2.5$

Table 3 The limit value of the reactive percentage error of meters on balanced load

Value of current		Power factor	Percentage error limits for meters of class		
Direct connection	Connection through		Class C	Class B	Class A
$0.1 I_b \leq I \leq I_{max}$	$0.05I_n \leq I \leq I_{max}$	1	$\pm 0.6$	$\pm 2.0$	$\pm 3.0$
$0.2I_b \leq I \leq I_{max}$	$0.1I_n \leq I \leq I_{max}$	0.5L	$\pm 1.0$	$\pm 2.0$	$\pm 3.0$

Table 4 The limit value of the reactive percentage error of meters on imbalanced load

Value of current		Power factor	Percentage error limits for meters of class
Direct connection	Direct connection		Class A
$0.1 I_b \leq I \leq I_{max}$	$0.05I_n \leq I \leq I_{max}$	1	$\pm 3.0$
$0.2I_b \leq I \leq I_{max}$	$0.1I_n \leq I \leq I_{max}$	0.5	$\pm 3.0$

### 3.3. Starting and no-load condition

#### 3.3.1. Starting

Under the power factor of 1.0 and started current, the instrument can be started and continuously measure (for multiple phase instrument, it will bring balanced load). If the instrument is designed based on measurement for dual directional energy, then it is applicable for each direction of energy.

DTSU666 three phase Smart meter (Din-rail)	ZTY0.464.1416
Operation manual	Page 6, Total 20

Table 5 start current

Meters for	Class of meter			Power factor
	Class C	Class B	Class A	
Direct connection	-	$0.004I_b$	$0.005I_b$	1
Connection through current transformers	$0.001I_b$	$0.002I_b$	$0.003I_b$	1

### 3.3.2. Test of no-load condition

When the voltage is applied with no current flowing in the current circuit, the test output of the meter shall not produce more than one pulse.

For this test, the current circuit shall be open-circuit and a voltage of 115 % of the reference voltage shall be applied to the voltage circuits.

The minimum test period  $\Delta t$  shall be

$$\Delta t \geq \frac{600 \times 10^6}{k \cdot m \cdot U_n \cdot I_{\max}} [\text{min}] \text{ for meters of class 0.5S or 1}$$

$$\Delta t \geq \frac{480 \times 10^6}{k \cdot m \cdot U_n \cdot I_{\max}} [\text{min}] \text{ for meters of class 2}$$

$k$  is the number of pulses emitted by the output device of the meter per kilovarhour(imp/kvar·h);

$m$  is the number of measuring elements;

$U_n$  is the reference voltage in volts;

$I_{\max}$  is the maximum current in amperes.

### 3.4. Electrical parameters

Table 6 Electrical parameters

Specified operating voltage range	$0.9U_n \sim 1.1U_n$	
Extended operating voltage range	$0.8U_n \sim 1.15U_n$	
Limit voltage range of operation	$0.0U_n \sim 1.15U_n$	
Power consumption of voltage	$\leq 1.5W$ 和 $6VA$	
Power consumption of current	$I_b < 10A$	$\leq 0.2VA$
	$I_b \geq 10A$	$\leq 0.4VA$
Data storage time after power interruption	$\geq 10$ years	

Note: meters intended to be used indoors.

## 4. Main function

DTSU666 three phase Smart meter (Din-rail)	ZTY0.464.1416
Operation manual	Page 7, Total 20

#### 4.1. Displayed function

From the displayed interface, the electrical parameter and energy data are all primary side data (that is, the multiplied by current and voltage ratios). The energy measuring value will be displayed seven bits, with the displaying range from 0.00kWh to 9999999MWh.

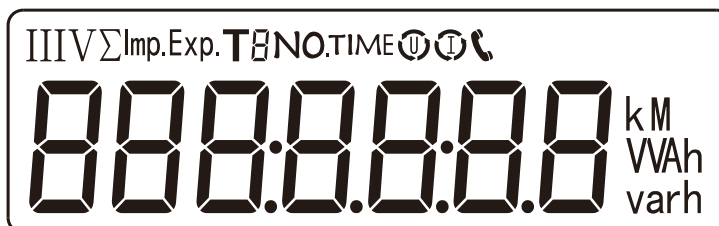

Figure 2 display

Table 7 Display interface

No.	Display interface	Instruction	No.	Display interface	Instruction
1		Combined active energy =10000.00kWh	12		Phase B current =5.001A
2		Positive active energy =10000.00kWh	13		Phase C current =5.002A
3		Reserve active energy =2345.67kWh	14		Combined phase active power =3.29kW
4		Protocol: DT/L645-2007 address = 000000000001	15		Phase A active power =1.090kW
5			16		Phase B active power =1.101kW
6		Protocol: MdoBus-RTU; address =001	17		Phase C active power



DTSU666 three phase Smart meter (Din-rail)	ZTY0.464.1416
Operation manual	Page 8, Total 20

		Baudrate=9600			=1.100kW
7		None parity, 1 stop bits	18		Combined phase power factor PFt=0.500
8		Phase A voltage =220.0V	19		phase A power factor PFa=1.000
9		Phase B voltage =220.1V	20		Phase B power factor PFb=0.500
10		Phase C voltage =220.20V	21		phase C power factor PFc=-0.500
11		Phase A current =5.000A			

NOTE1: Combined active energy = Positive active energy + Reserve active energy。

NOTE2: The communication address of Modbus protocol is 1 decimal data (1 ~ 247), and the factory default baud rate is 9600bps, N.8.1; E1 means even check 1 stop bit, O1 means odd check 1 stop bit Two stop bits, N1 means one stop bits without check;

NOTE3: The above interface is used to show the meaning of the display content. Due to the different functions of the instrument, the display symbols will increase or decrease.

#### 4.2. Programming function

##### 4.2.1. Programming function

Table 8 Programming Parameter

Parameter	Value range	Description
$Ct$	1~9999	Current ratio, used for setting the input loop current ratio: When the current is connected to the line via the transformer, $Ct$ =the rated

DTSU666 three phase Smart meter (Din-rail)	ZTY0.464.1416
Operation manual	Page 9, Total 20

		current of the primary loop / the rated current of the secondary circuit; When the current is directly connected to the line, Ct shall be set as 1.
<i>Pt</i>	0.1~999.9	Voltage ratio, used for setting the voltage ratio of the input loop; When the voltage is connected to the line via the transformer, Pt= the rated voltage of the primary loop / the rated voltage of the secondary circuit; When the voltage is directly connected to the line, Pt shall be set as 1.0.
<i>Prot</i>	1: 645; 2: n.2; 3: n.1; 4: E.1; 5: O.1;	Settings for communication stop bit and Parity bits: 1: 645 mode; 2: None parity, 2 stop bits, n.2; 3: None parity, 1 stop bit, n.1; 4: Even parity, 1 stop bit, E.1; 5: Odd parity, 1 stop bit, O.1;
<i>bAud</i>	0: 1.200; 1: 2.400; 2: 4.800; 3: 9.600;	Communication baud rate: 0: 1.200 bps; 1: 2.400 bps; 2: 4.800 bps; 3: 9.600 bps;
<i>Addr</i>	1~247	Communication address
<i>nEt</i>	0: n.34; 1: n.33;	Option for wiring mode: 0: n.34 represents three phase four wire; 1: n.33 represents three phase three wire.
<i>PLuS</i>	0:P; 1:Q;	Pulse output: 0: active energy pulse; 1: reactive energy pulse; 2: Others.
<i>dISP</i>	0~30	Display in turns(second) 0: Timely display; 1~30: Time interval of actual display.
<i>bLcd</i>	0~30	Backlight lighting time control (second) 0: Normally light; 1~30: backlight lighting time without button operation

#### 4.2.2. Programming operation

Button description: “SET” button represents “confirmation”, or “cursor shift” (when input digits), “ESC” button represents “exit”, “→” (“ ”) button represents “add”. The input code is (default 701).

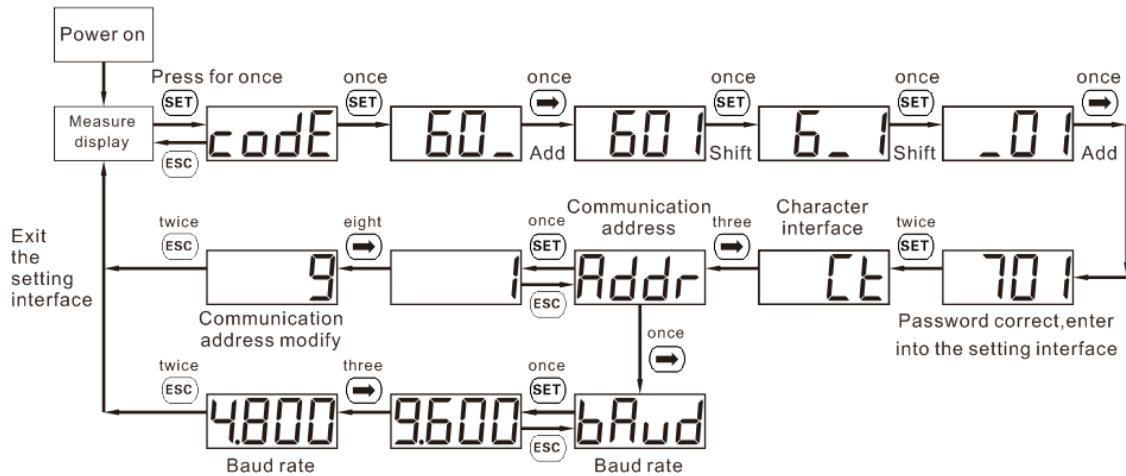

Figure 3 Setting examples for communication address and Baud Rate

When input digits, “**SET**” can be used as cursor “\_” motion button; “**→**” is “add” button, “**ESC**” is Exit the programming operation interface or switch to the character interface from digit modification interface, add from the beginning after setting the digit to the maximum value.

#### 4.3. Communication function

Characterized with a RS485 communication interface, the baud rate can be changed between 1200bps, 2400bps, 4800bps and 9600bps. It conforms to DL/T645<the communication protocol of the multifunction energy meters> or ModBus-RTU protocol requirements.

Factory default communication parameter is ModBus-RTU protocol, the baud rate is 9600bps, with the calibration bit and stop bit to be n.1, and the instrument address to be 1. The following table is the common ModBus protocol address table, can be asked for specified communication protocol by calling. ModBus\_RTU protocol read command is 03H, write command is 10H.

Table 9 ModBus protocol address table

Parameter address	Parameter code	Instructions of parameters	Data type	Data length Word	Read Write
Keyboard parameters (specific parameters see the instructions of programming parameters, the actual value with (*) parameter= communication parameter value × 0.1)					
0000H	REV.	Software Version	Signed	1	R
0001H	UCode	Programming code codeE(1~9999)	Signed	1	R/W
0002H	CLrE	Power reset CLr.E(1:energy clear)	Signed	1	R/W

DTSU666 three phase Smart meter (Din-rail)	ZTY0.464.1416
Operation manual	Page 11, Total 20

0003H	net	Network selection (0:three phase four wire,1:three phase three wire)	Signed	1	R/W
0006H	<i>I<sub>rAt</sub></i>	Current transformer rate IrAt(1~9999)	Signed	1	R/W
0007H	<i>U<sub>rAt</sub></i>	Voltage transformer rate UrAt (*) (1~9999 represents voltage ratio 0.1~999.9)	Signed	1	R/W
000AH	Disp	Rotating display time (s)	Signed	1	R/W
000BH	B.LCD	Backlight time control (s)	Signed	1	R/W
000CH	Endian	Reserve	Signed	1	R/W
002CH	Protocol	Protocol switching (1:DL/T645;2:n.2;5:n.1;6:E.1;7:o.1)	Signed	1	R/W
002DH	<i>bAud</i>	Communication baud rate bAud (0:1200;1:2400;2:4800;3:9600;)	Signed	1	R/W
002EH	<i>Addr</i>	Communication address Addr(1~247)	Signed	1	R/W
Electricity data on the primary side					
150AH	Uab	Three phase line voltage data, Unit V	float	2	R
150CH	Ubc		float	2	R
150EH	Uca		float	2	R
1510H	Ua	Three phase phase voltage data, Unit V (Invalid for three phase three phase)	float	2	R
1512H	Ub		float	2	R
1514H	Uc		float	2	R
1516H	Ia	Three phase current data, Unit A	float	2	R
1518H	Ib		float	2	R
151AH	Ic		float	2	R
151CH	Pt	Combined active power, Unit kW	float	2	R
151EH	Pa	A phase active power, Unit kW	float	2	R
1520H	Pb	B phase active power, Unit kW (Invalid for three phase three phase)	float	2	R
1522H	Pc	C phase active power, Unit kW	float	2	R
1524H	Qt	Combined reactive power, Unit kvar	float	2	R
1526H	Qa	A phase reactive power, Unit kvar	float	2	R

DTSU666 three phase Smart meter (Din-rail)	ZTY0.464.1416
Operation manual	Page 12, Total 20

1528H	Qb	B phase reactive power, Unit kvar (Invalid for three phase three phase)	float	2	R
152AH	Qc	C phase reactive power, Unit kvar	float	2	R
1534H	PFt	Combined power factor(positive number: inductive, negative number: capacitive)	float	2	R
1536H	PFa	A phase power factor(positive number: inductive, negative number: capacitive) (Invalid for three phase three phase)	float	2	R
1538H	PFb	B phase power factor(positive number: inductive, negative number: capacitive) (Invalid for three phase three phase)	float	2	R
153AH	PFc	C phase power factor(positive number: inductive, negative number: capacitive) (Invalid for three phase three phase)	float	2	R
154EH	Freq	Frequency, Unit Hz	float	2	R
Electricity data on the primary side					
2000H	Uab	Three phase line voltage data, Unit V( $\times 0.1V$ )	float	2	R
2002H	Ubc		float	2	R
2004H	Uca		float	2	R
2006H	Ua	Three phase phase voltage data, Unit V V( $\times 0.1V$ ) (Invalid for three phase three phase)	float	2	R
2008H	Ub		float	2	R
200AH	Uc		float	2	R
200CH	Ia	Three phase current data, Unit A( $\times 0.001A$ )	float	2	R
200EH	Ib		float	2	R
2010H	Ic		float	2	R
2012H	Pt	Combined active power, Unit W( $\times 0.1W$ )	float	2	R
2014H	Pa	A phase active power, Unit W( $\times 0.1W$ )	float	2	R
2016H	Pb	B phase active power, Unit W( $\times 0.1W$ ) (Invalid for three phase three phase)	float	2	R
2018H	Pc	C phase active power, Unit W( $\times 0.1W$ )	float	2	R
201AH	Qt	Combined reactive power, Unit var( $\times 0.1var$ )	float	2	R
201CH	Qa	A phase reactive power, Unit var( $\times 0.1var$ )	float	2	R
201EH	Qb	B phase reactive power, Unit var( $\times 0.1var$ ) (Invalid for three phase three phase)	float	2	R
2020H	Qc	C phase reactive power, Unit var( $\times 0.1var$ )	float	2	R

DTSU666 three phase Smart meter (Din-rail)	ZTY0.464.1416
Operation manual	Page 13, Total 20

202AH	PFt	Combined power factor(positive number: inductive, negative number: capacitive) ( $\times 0.001$ )	float	2	R
202CH	PFa	A phase power factor(positive number: inductive, negative number: capacitive) (Invalid for three phase three phase) ( $\times 0.001$ )	float	2	R
202EH	PFb	B phase power factor(positive number: inductive, negative number: capacitive) (Invalid for three phase three phase) ( $\times 0.001$ )	float	2	R
2030H	PFc	C phase power factor(positive number: inductive, negative number: capacitive) (Invalid for three phase three phase) ( $\times 0.001$ )	float	2	R
2044H	Freq	Frequency, Unit Hz( $\times 0.01\text{Hz}$ )	float	2	R
Power primary side data					
101EH	ImpEp	(current) positive total active energy(kWh)	float	2	R
1020H	ImpEpA	(current) positive A active energy(kWh)	float	2	R
1022H	ImpEpB	(current) positive B active energy(kWh)	float	2	R
1024H	ImpEpC	(current) positive C active energy(kWh)	float	2	R
1028H	ExpEp	(current) negative total active energy(kWh)	float	2	R
102AH	ExpEp A	(current) negative A active energy(kWh)	float	2	R
102CH	ExpEp B	(current) negative B active energy(kWh)	float	2	R
102EH	ExpEp C	(current) negative C active energy(kWh)	float	2	R

Note 1: Single-precision floating point adopts standard IEEE754 format, total 32 bit(4 word). The single-precision floating point mode is assumed to be ABCD(high type in the front, low byte behind).

#### 4.4. Energy measurement function

The horizontal axis of the measurement plane represents the current vector I (fixed on the horizontal axis), and the instantaneous voltage vector is used to represent the current power transmission. Compared with the current vector I, it has phase angle  $\phi$ . The counter-clockwise direction  $\phi$  angle is positive.

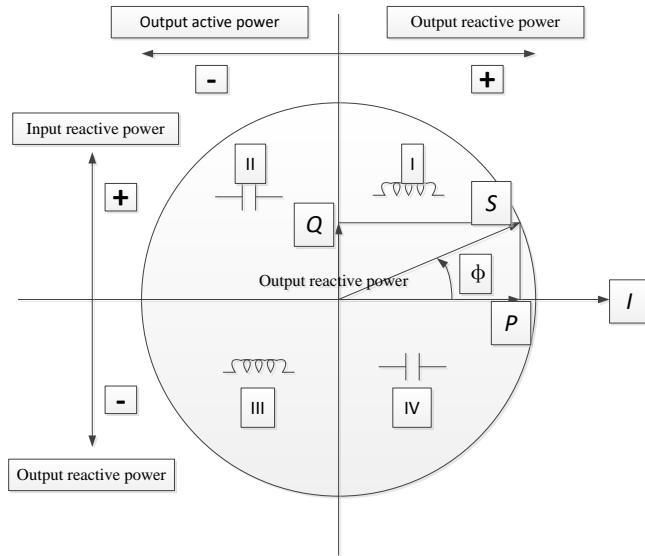

Figure 5 Measurement schematic diagram for energy four quadrants

### 5. Outline and installation size

Table 10 Installation size

Model	modulus	Outline size (length× width× height) mm	Installation size (din rail)
DTSU666	4	100×72×65	DIN35 din rail
DSSU666	4		

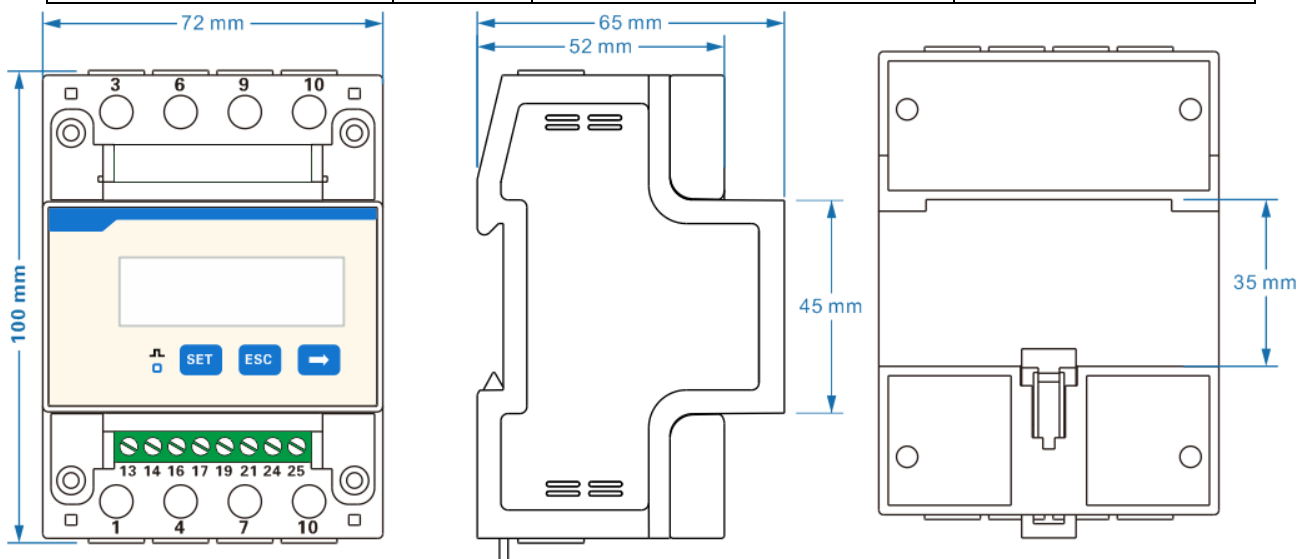

Figure 6 Outline size diagram

Note1: The undeclared tolerance is  $\pm 1$  mm.

Note2: only indicates the size, and the shape of different specifications is slightly different.

DTSU666 three phase Smart meter (Din-rail)	ZTY0.464.1416
Operation manual	Page 15, Total 20

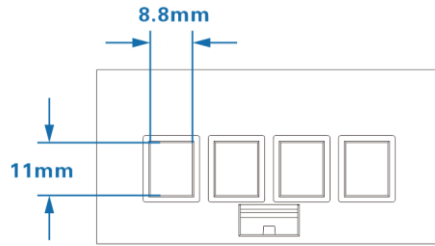

Figure 7 current cable terminal (Conductor Cross-sectional Area Range  $\leq 16 \text{ mm}^2$  )

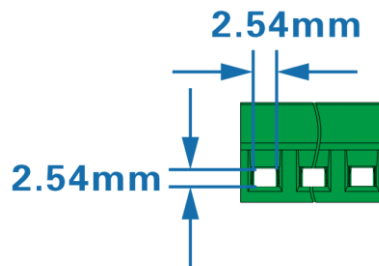

Figure 8 RS485 cable terminal (Conductor Cross-sectional Area Range 0.25-1mm<sup>2</sup> )

## 6. Installation and operation manual

### 6.1. Inspection Tips

When unpacking the carton, if the shell has obvious signs caused by severe impact or falling, please contact with the supplier as soon as possible.

After the instrument being removed from the packing box, it should be placed on a flat and safe plane, facing up, not overlaying for more than five layers. If not installed or used in a short time, the electric meter shall be packed and placed to the original packing box for storage.

The waterproof and dustproof rating of the front panel of the Meter is IP51, it shall be used in the meter box meeting the requirements of IP51.

### 6.2. Installation and tips

#### 6.2.1. Installation and Inspection

If the model No or configuration in the original packing box is not in accordance with the requirement, please contact with the supplier. While, if the inner package or shell has been damaged after removing the instrument from the packing box, please do not install, power on the instrument, please contact with the supplier as soon as possible, instead.

#### 6.2.2. Installation



DTSU666 three phase Smart meter (Din-rail)	ZTY0.464.1416
Operation manual	Page 16, Total 20

It requires experienced electrician or professional personnel to install it and you must read this operation manual. During the installation, if the shell has obvious damage or marks caused by violent impact or falling, please do not install it or power on and contact with the supplier as soon as possible.

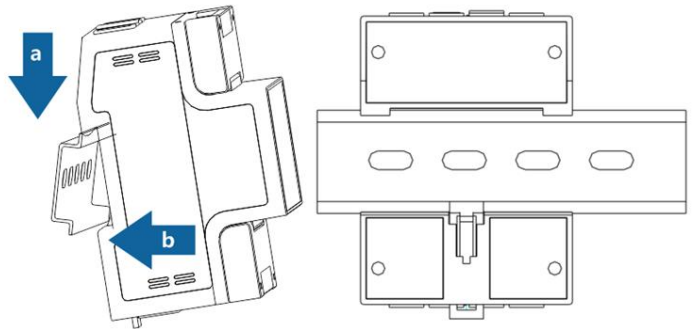

Figure 9

6.3. Typical wiring

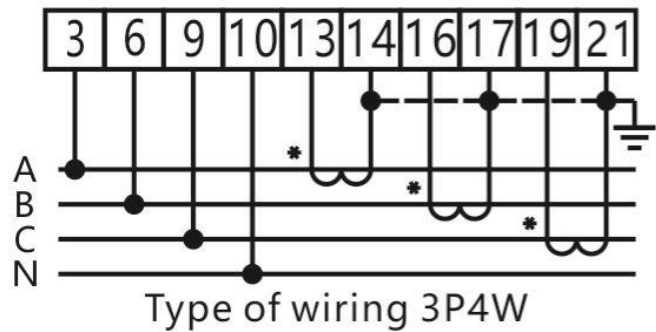

Figure 30 Three phase four wire: Connection through current transformers

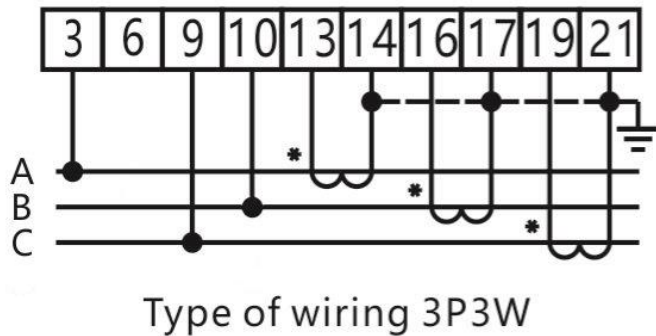

Figure 41 Three phase three wire: Connection through current transformers

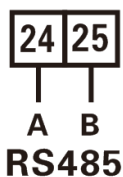

Figure 52 RS485

DTSU666 three phase Smart meter (Din-rail)	ZTY0.464.1416
Operation manual	Page 17, Total 20

◆ Voltage signal

3-----UA (Phase A voltage input terminal)

6 -----UB (Phase B voltage input terminal)

9-----UC (Phase C voltage input terminal)

10-----UN (Phase N voltage input terminal)

◆ Current signal:

13----IA\*(Phase A current input terminal)

14----IA (Phase A current output terminal)

16----IB\*(Phase B current input terminal)

17----IB (Phase B current output terminal)

19----IC\*( Phase C current input terminal)

21----IC (Phase C current output terminal)

◆ RS485 Communication wire

24-----A (RS485 Terminal A)

25-----B (RS485 Terminal B)

7. Diagnosis, analysis and elimination for common faults

Fault phenomenon	Reason analysis	Elimination
No display when powered on	<ol style="list-style-type: none"> <li>1、 Incorrect wiring</li> <li>2、 Abnormal voltage for the instrument</li> </ol>	<ol style="list-style-type: none"> <li>1. If it is wrongly connected, please reconnect based on the right wiring mode (see the wiring diagram).</li> <li>2. If the supplied voltage is abnormal, please choose the specified voltage.</li> <li>3. If not the above problems, please contact with the local supplier.</li> </ol>
Abnormal RS485 communication	<ol style="list-style-type: none"> <li>1. RS485 communication cable is opened, short circuit or reversely connected.</li> <li>2. Address, baud rate, data bit and check bit is not in accordance with the host computer.</li> <li>3. The end of RS485 communication cable has not been matched with resistance (when the distance over than 100 meters)</li> </ol>	<ol style="list-style-type: none"> <li>1. If there is any problem with the communication cable, please change it.</li> <li>2. Set the address, baud rate, data bit and check bit through buttons and confirm it is the same with the host computer, then set the operation to be “parameter settings”.</li> <li>3. If the communication distance is over than 100</li> </ol>

DTSU666 three phase Smart meter (Din-rail)	ZTY0.464.1416
Operation manual	Page 18, Total 20

	4. Not matched with the communication protocol order of the host computer	meters, and the communication parameter settings are the same as the host computer, but cannot be communicated, then please lower the baud rate or add a resistance of 120Ω at the start terminal and ending terminal.
Abnormal data for the electrical parameter (voltage, current, power, etc.)	<ol style="list-style-type: none"> <li>1. The transformer's ratio hasn't been set, and the instrument displays the secondary side data.</li> <li>2. Wrong wiring.</li> </ol>	<ol style="list-style-type: none"> <li>1. If setting the transformer ratio, please set the voltage ratio and current ratio based on "parameter setting"</li> <li>2. If wrongly connected, please connect the voltage and current of phase A, B and C to the wiring terminal of the instrument.</li> </ol>
Abnormal data for the electrical parameter read by communication (voltage, current, power, etc.)	<ol style="list-style-type: none"> <li>1. Data read by communication is secondary side data, without transformer ratio.</li> <li>2. Wrong analysis for data frame</li> </ol>	<ol style="list-style-type: none"> <li>1. Multiply the data read by communication with the voltage ratio and current ratio.</li> <li>2. Analyze the data frame based on the format of the communication protocol, please pay attention to the mode of the big and small end of data.</li> </ol>

## 8. Transportation & Storage

When transporting and unpacking the products, please confirm they are not severely impacted, transporting and storing based on Transportation, basic environmental conditions and testing methods for instrument and meters of JB/T9329-1999.

The instrument and accessories shall be stored in the dry and ventilated places, to avoid humidity and corrosive gas erosion, with the limited environmental temperature for storage to be -40℃ ~ +70℃ and relative humidity not exceeding 85%.

## 9. Maintenance & Service

DTSU666 three phase Smart meter (Din-rail)	ZTY0.464.1416
Operation manual	Page 19, Total 20

---

We guarantee free reparation and change for the multi-meter if found any unconformity with the standard, under circumstance of that the users fully comply with this instructions and complete seal after delivery within 18 months.

---

DTSU666 three phase Smart meter (Din-rail)	ZTY0.464.1416
Operation manual	Page 20, Total 20

---

Dear clients,

Please assist us: when the product life is end, to protect our environment, please recycle the product or components, while for the materials that cannot be recycled, please also deal with it in a proper way. Really appreciate your cooperation and support.

Name of Company: Zhejiang Chint Instrument & Meter Co., Ltd.

Address: Wenzhou Bridge Industrial Zone, Yueqing, Zhejiang, China.

Zip Code: 325603

Telephone: 0577-62877777

Fax: 0577-62891577

Service hotline: 4008177777

Fake Complaint: 0577-62789987

Website: <http://www.chint.com>

Email: [ztyb@chint.com](mailto:ztyb@chint.com)

Date of Issue: March.2021

No.:ZTY0.464. 1416V1